



# KOBRA



SIGRC53  
**SIG**  
CRAFTMAN'S KIT

## BUILDING AND FLYING INSTRUCTIONS

**Sig Mfg. Co., Inc....401-7 South Front Street....Montezuma, Iowa 50171**

The Kobra is a sort of Kougat, Jr. with its own individual lines and character. Like its bigger brother, it is fast and maneuverable, so we don't recommend the design as a beginner's trainer. Although very aerobatic, it is also stable and easy to manage. The built-in washout is automatically incorporated as the wing is built from the kit parts. This decrease in wing incidence at the tip as compared to the root rib helps prevent tip stall and improves slow speed flight performance.

The .25 size engines used in the prototypes gave excellent stunt capability and good vertical maneuvers. Takeoffs were made from a grass field without difficulty. A .19 would be okay for sport flying from smooth surfaces and as a transition trainer. A .30 cu.in. engine provides high speed action with air-show type aerobatics. A mild .35 will give similar performance and a hot one produces spectacular results. Any larger engine is not required and is not recommended.

### ABOUT THE BUILDING SEQUENCE

The quickest and most efficient way to complete a model is to work on several pieces at the same time. While the glue is drying on one section, you can start on or proceed with another part. Work can even go forward on several sections of the same assembly at the same time, such as the front and rear sections of the fuselage. We occasionally get suggestions that our instructions should be in exact step-by-step building sequence. But this would result in many sentences starting, "While the glue is drying on the fuselage, move the the wing.....etc." and a lot of jumping back and forth between assemblies with no consistent pictorial progression. Also a pre-selected building sequence by our choice might not suit your workshop space and time allotments. Therefore, we feel the present system of covering main assemblies in a unit works out best for the majority of kit builders. So keep in mind that the numbering sequence used in these instructions was chosen as the best way to explain the building of each major assembly and is not intended to be followed exact one-two-three fashion. Start on the wing at No.1 and after doing as many steps as is convenient, flip over to "Fuselage Construction" and do a step or two or three, then over to "Tail Assembly" and so forth. You will, of course, arrive at points where you can go no farther until another component is available. For example, you need a nearly completed and mounted wing before the fuselage can be entirely completed.

The way to understand these relationships is to read the instructions completely and study the full size plan before beginning to work. Any reference to right or left refers to right or left as if seated in the cockpit.

## SOME BUILDING SUGGESTIONS

Cut all long pieces of balsa first, followed by medium lengths before cutting up any full-length strips into short pieces. The 3/16" square sticks are intentionally oversize (actually 13/64") to allow for shaping the trailing edge to correct airfoil contour. Sort the different sizes of sticks into individual piles to avoid confusion during building.

A piece of Celotex-type wallboard or foam board makes a handy building board, into which pins can easily be pushed. Lay the building board on a table with a flat and untwisted top. Pins can be pushed through all pieces in the kit without any lasting damage. Don't be afraid to use plenty of pins when planking. The holes will fill up during sanding and doping. Use Sig-Bond for general construction except where the instructions call for epoxy.

A single edge razor blade is best for cutting sticks. Use a modeling knife for cutting out sheet balsa parts.

### YOU CAN'T GET ALONG WITHOUT A GOOD SANDING BLOCK

An indispensable tool for proper construction is a large sanding block sized to take a full sheet of sandpaper. Use several wood screws along one edge to hold the sheet in place. Use the block to bring all parts and sticks to final, exact fit. We recommend 80-grit garnet paper for use on the block during general construction. You can switch to 100-grit, followed by 220 silicone paper for final finish just before covering.

In addition to the large block, there are places where a smaller one is handy. Also, a sandpaper "file" can be made by gluing sandpaper to a flat spruce stick for working tight-places.

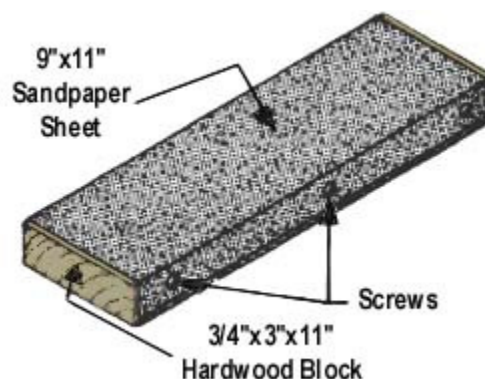

### CUTTING OUT PRINTED PARTS

A jig saw is best for the job. Cut just outside the lines, leaving all of the black line on the part. When fitting the part into place in the model, use the sanding block to bring the edges to an exact fit. If a modeling knife is used to cut the parts, don't cut too close to the lines - leave some extra wood outside the line. True up and finish the edge with the sanding block.

### ABOUT PRINTED WOOD PARTS

Some years ago we had kits featuring die-cut parts in both thick and thin sizes. If the thick parts were cut from dry wood, the wood often crushed or crinkled on the edges, even when using a brand new die. If the thick parts were cut from wet wood there was an improvement - though many of them still crushed - and the swelled wet wood parts changed shape after drying, making them inaccurate. So we asked modelers if they would rather have the parts printed on the wood instead. They could be cut in a few minutes with a saw or modeling knife and thus avoid any "die-crunching." Most voted in favour of this idea.

To answer the question we are sometimes asked - no, we do not print parts on wood to save money. It is actually more expensive to print the parts using a silk screen press than it is to run an equivalent sheet through our automatic feed die cutting machine. If we hand-sawed the parts it would be even more expensive and the labor cost would have to be added to the kit price. We believe that most modelers would rather cut their own out and save the cost. Since there are not many thick parts in our average kit, it really doesn't consume a lot of the total building time for the builder to do the parts.

### USE ENOUGH GLUE!

Instant glues assemble a framework quickly but may not be good enough to withstand engine vibration if improperly used. Thin cyanoacrylate should only be applied to perfectly fitted joints, otherwise use gap-filling types. If you assemble with instant glue, we think it is a good idea to go over the framework with a normal slow dry glue like Sig-Bond and fillet all of the joints on the outside. One mistake often made is inadequate amounts of glue on large mating surfaces to completely cover them when the parts are joined. A structure does not have full strength unless all of the parts are glued to each other. For example, the wing spar webs must not just be glued to the spars but the outside wing sheeting must be glued to the ends of the webs as well as to the spars.

## WING CONSTRUCTION

1.
  - a. Cut the bottom wing spar from the 3/16"x3/8" balsa strip stock. Cut it to exact length on the plan and save the scrap ends for later use on the tail.
  - b. Pin it in place on the plan.

All ribs must touch the board at X. The jig tab must sit firmly on the board.

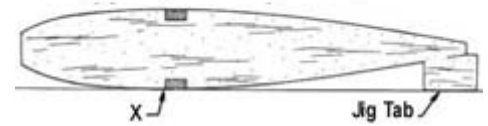

2. Pin and glue the ribs in place on the bottom spar.

3. Make certain that the rib tabs are contacting the building board. This assures accurate alignment of the built in washout.

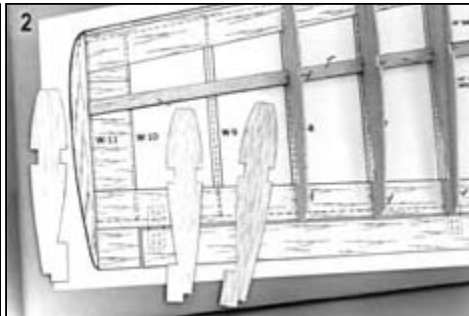
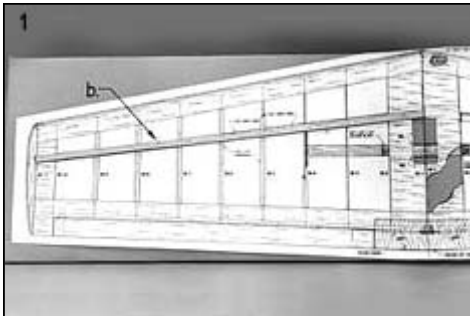

4.
  - a. Add the top spar. Cut it to exact length and save the scrap ends.
5.
  - a. Pin and glue the 3/16" sticks into the trailing edge notch. Save the scrap ends for use in the fuselage,

In designing the Kobra it was discovered that standard 3/16" sq. sticks were not quite large enough for the wing trailing edge. We cut special 13/64" oversize sticks for the kit but refer to them as 3/16" sq. on the plan and in these instructions, since the appearance is about the same as a stock 3/16" piece of wood.

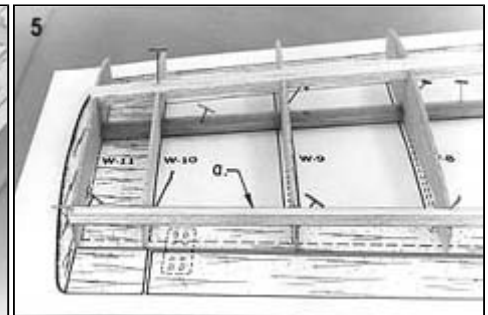
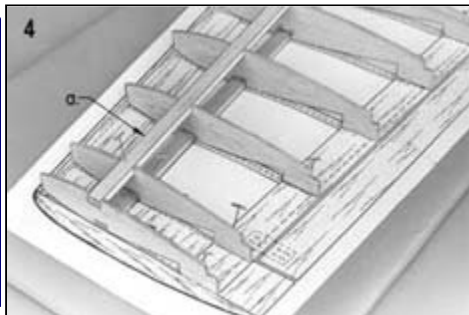

NOTE: Do not press down hard on the jig tabs during this and subsequent steps. They will break if overloaded. Support the rib with your fingers when pushing in pins.

6. Carefully bevel and even the front edges of the ribs so they will contact the leading edge accurately.
7. Using a straight edge, cut the taper into the leading edge stick as shown in the drawing. The reason we do not cut this taper in at the factory is because of the tendency of balsa sticks to bow when they are cut from the raw wood block. Tapering them just before building into the structure avoids this problem.

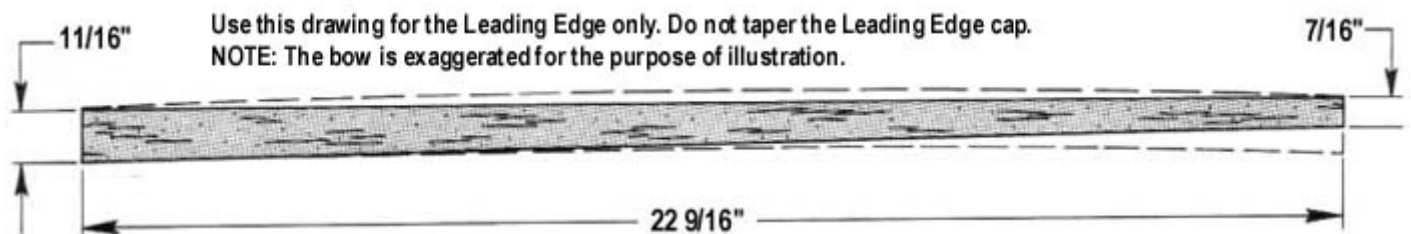

8.
  - a. Glue and pin the tapered leading edge in place.
9.
  - a. 3/32"x2-3/4"x12" wood (it may sometimes be 3" wide) is provided for the wing spar webs. Mark the depth required for each rib bay and cut off the strip. The grain runs vertically.

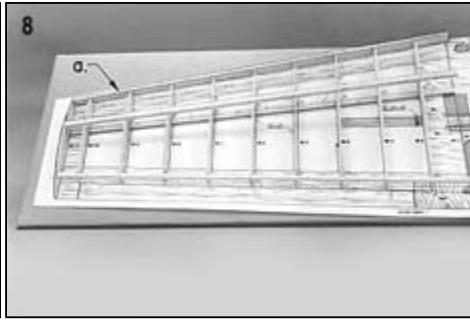
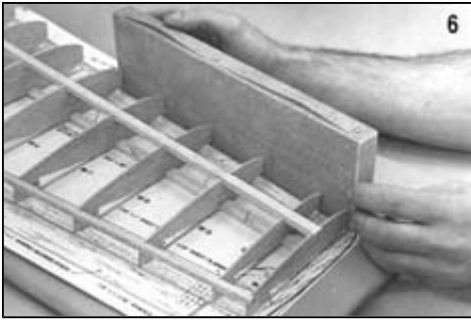

10. Fit the strip into the bay by carefully trimming the end.

11. Glue in place.

- 12.
- a. Repeat the process in the next two rib bays.
  - b. The last web is cut from scrap 1/16" sheet wood.

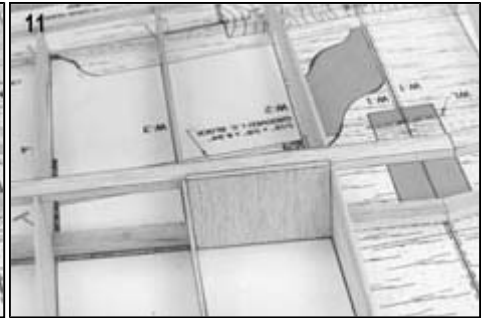
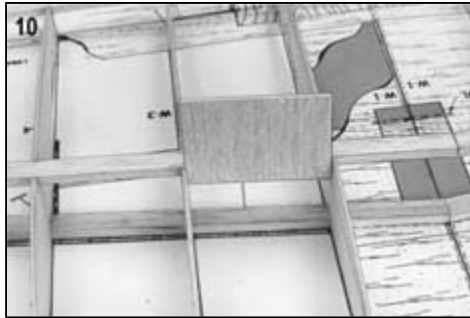

13. Trim the tops of the web strips flush with the spar.

14. Using the dihedral gauge, mark the leading edge for trimming. Place the bottom corner of the gauge on the centerline.

- 15.
- a. Do the same thing with the spars.
  - b. Repeat the process on the trailing edge.

Remove the first wing half from the board and repeat Steps 1 through 15 on the opposite wing plan half. Leave one wing half pinned to the board on the plan. Now proceed as follows:

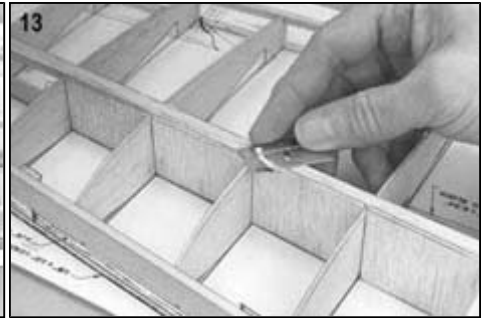
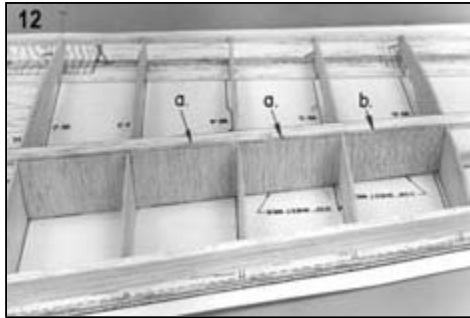

- 16.
- a. Pin a 1-7/8" high squared block to the opposite end of the plan.
  - b. Have the back corner right on the trailing edge line so that the tip rib can be accurately positioned front and rear.

17 Set the loose wing half in place on the block and check the fit at the center section. It may be necessary to touch up the spar ends for good fit.

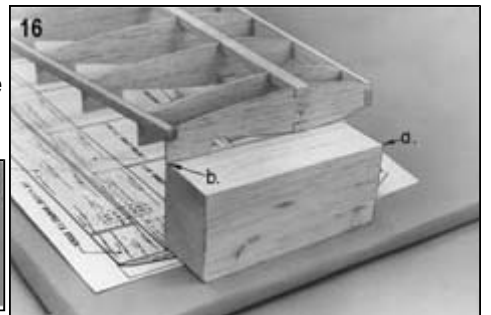

18 Use epoxy glue to join the wing halves.

- 19.
- a. Lay out the pattern for the front dihedral brace on the 5/16"x1"x3-7/8" piece of balsa provided.
  - b. Saw out the brace.

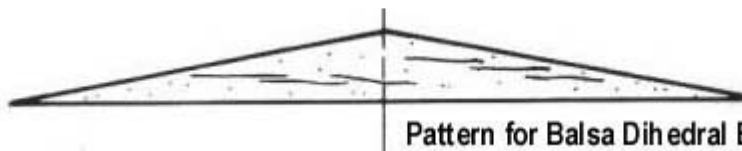

Pattern for Balsa Dihedral Brace Block

20. a. Fit the brace into place by touching it up with a sanding block.
- b. Glue it to the leading edge.

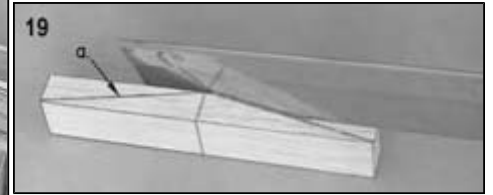

21. Fit the two center section ribs into place. They will need trimming on the front to fit against the brace. We did not do this on the die-cut because the brace will vary in position according to the individual construction.

22. As the ribs progress toward the tip there is a slight protrusion of the spar at the rear because of the washout. Trim rear of the spar to conform to the rib contours and touch up with a small sanding block.

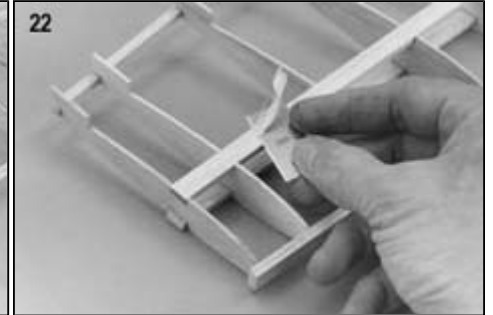
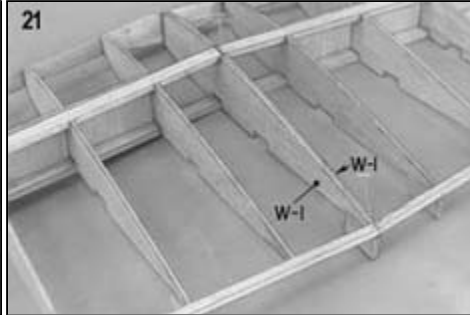
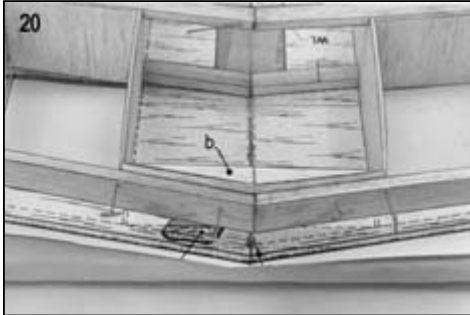

23. Glue pieces of 3/16" sheet scrap to the trailing edge in the center section as shown. Shape the rib and trailing edge contour. This provides a filled in area for later drilling of the wing bolt holes.

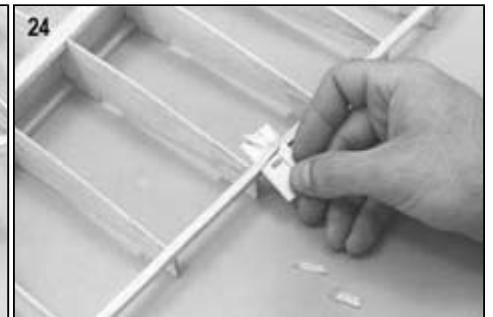
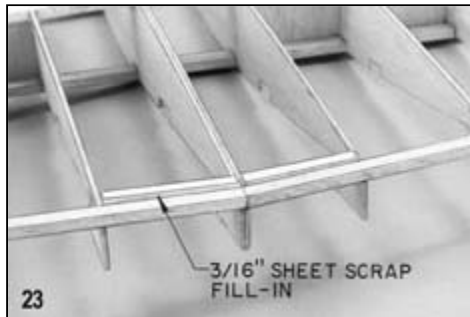

24. Trim the trailing edge to airfoil contour.
25. Touch up with a sanding block.

26. Trim the leading edge to airfoil contour and touch up with a sanding block.

27. Complete the spar webbing in the center section, using a 3/32" scrap from the rib WS die-cut sheet.

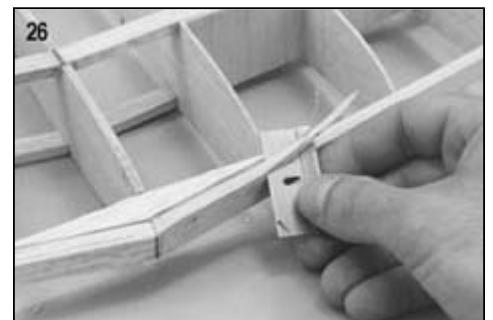
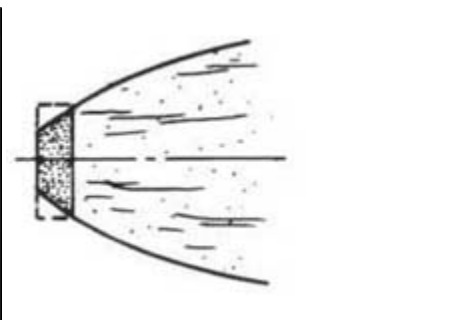

28. Glue a strip of 1/16"x1" planking on the trailing edge. (Save the scrap ends.) Have the wing pinned down to a flat surface and make use of the jig tabs. This is a critical piece of wood in locking in the washout angle. If you put it on with the wing off the jig tabs and building board, you could twist the structure out of alignment. Don't use a water base glue which may bow or warp the wood. We used epoxy which definitely locks in the washout. Gap-filling cyanoacrylate "super" glue would also be a possibility on this piece. Look at the plan and picture 58 and see where plywood part WP will be glued on. Don't glue on this area so that it will later be easier to trim out the opening for WP in the 1/16" trailing edge planking.

29. Remove the jig tabs from the bottom of the ribs.

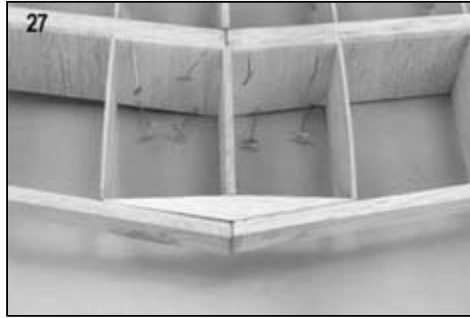

30. a. Glue on the bottom 1/16"x1" planking strip. Save the scrap end. Be careful not to twist the structure when pinning the planking in place.

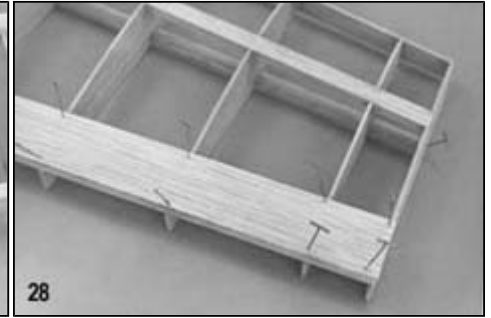

31. a. Glue the leading edge 1/16"x1" planking to the leading edge. Allow to dry.

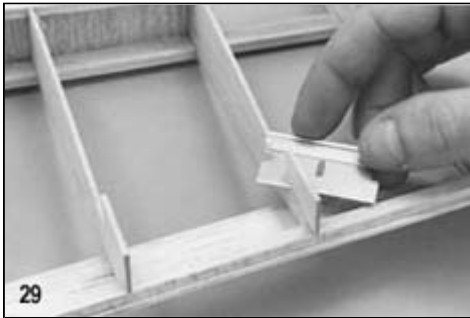

32. a. Apply glue to the ribs and curve the leading edge sheet into place, holding it down with a pin at each rib. If it will not curve into place dry, dampen the top of the sheet with water to make it more pliable.

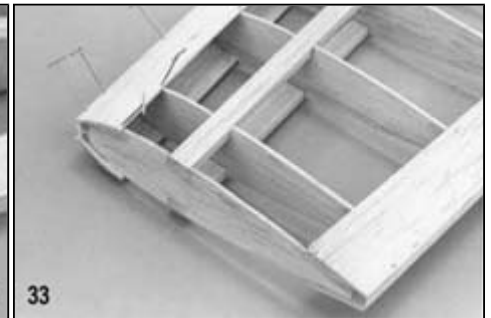

33. Repeat the process on the opposite side of the leading edge.

34. a. Glue the landing gear blocks into the wing.



35. a. Glue P-2 in place on the landing gear block at rib 2.

b. Glue P-4 in place at Rib 4.

36. a. Glue the 3/8"x5/8"x3/4" hardwood landing gear anchor block in place on top of the landing gear block against P-2.

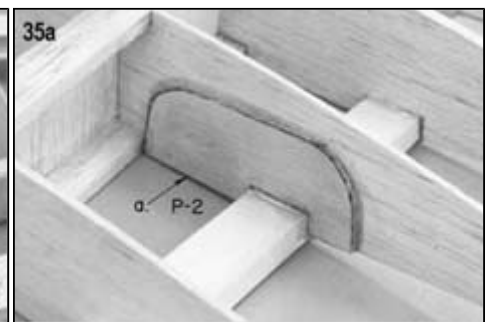

37. With an epoxy glue joint where the landing blocks join, the center section of this model is probably strong enough. For those who worry about possible bad joints we show a joint brace WL to be made from scrap 3/32" plywood. To install, cut a slot in the center ribs 3/32" wide on each side of the landing gear block.

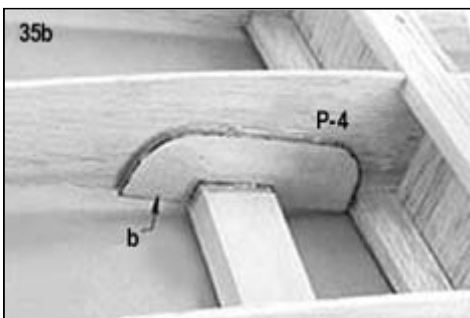

38. Epoxy glue the braces to each side of the block.

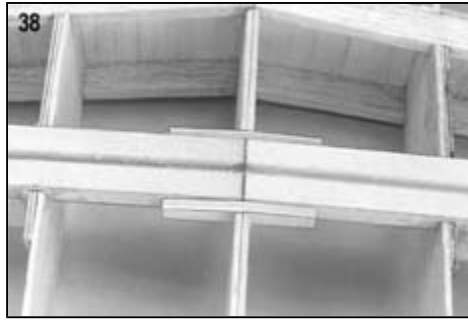

39. Add the 1/8"x5/8" leading edge cap to the front of the wing.



40. Mark the flat area on the front of the center section and saw it off.

41. Shape the leading edge cap to airfoil contour.

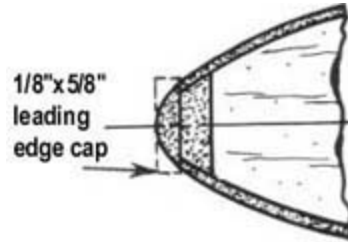

42. Begin sheeting the center section bottom with 1/16"x3" sheet wood.

**NOTE:**  
Look ahead to pictures 132 and 133 for further information about the wing aileron servo compartment and the installation of plastic servo mounts.

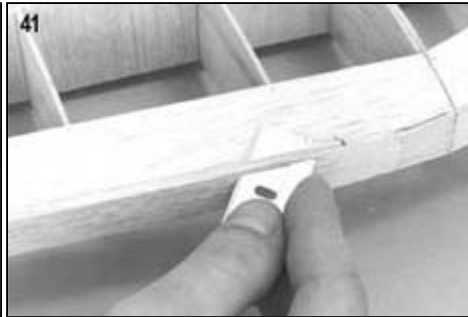
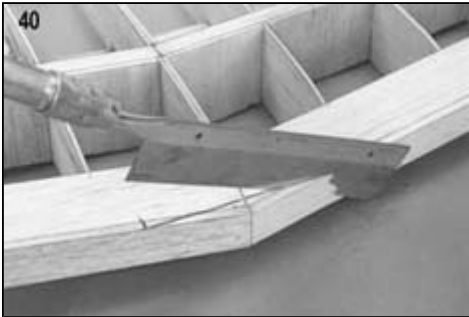

43. Complete the bottom planking.

44. a. Cut out the center ribs to provide space for the servo installation. Length depends on your servo size.  
b. Add ribs WS.

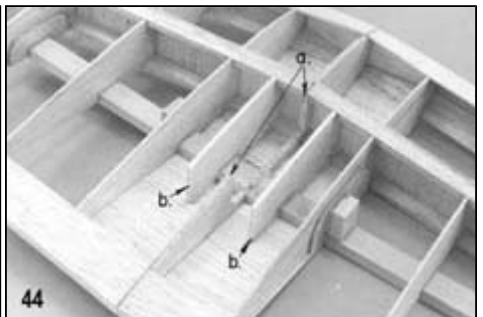

45. a. Make a rear for the servo compartment from 3/32" scrap.

46. Sheet the top of the center section with 1/16" sheet, leaving the servo compartment open.

47. Complete the top planking.



48. Sheet the tips on top and bottom with 1/16" sheet balsa.

49. Cut a piece of 1-3/32" wide trailing edge stock provided. Sand it as shown by the drawing so as to center on the tip rib and glue in place.

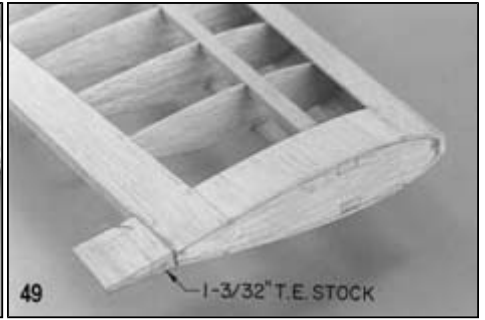
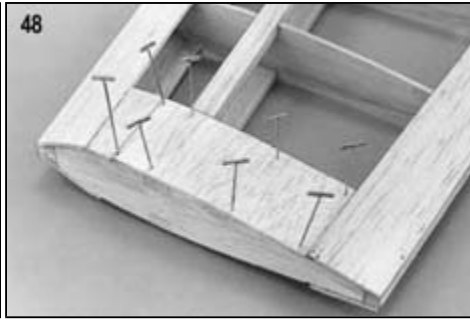

50. Trace the wing tip pattern on the 1/2"x1-1/8"x6-1/2" wing tip blocks. Carve the block to this line.

51. Glue the blocks to the tip ribs.

52. Carve to the shape of the tip rib.

53. Carve the tip to a rounded shape and sand smooth.

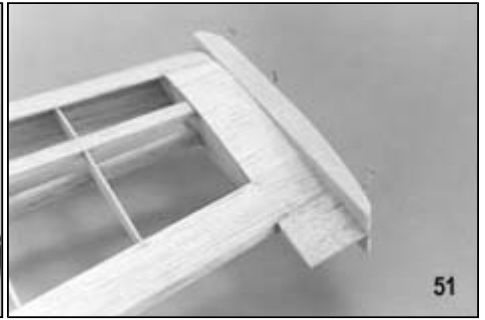
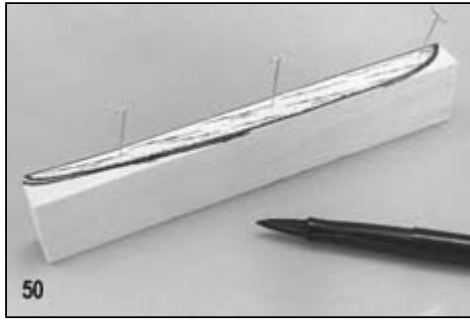

54. Using a 1/8" bit, drill through the landing gear anchor block. The hole should be vertical to the bottom face of the landing gear block. Cut a radius in the groove hole to pass the corner of the bent wire.

55. a. Fill in the end of the block groove with scrap to provide an anchor point for the covering.

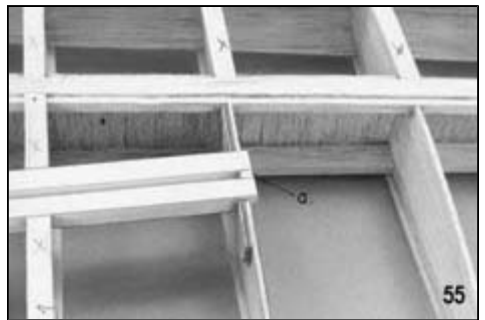
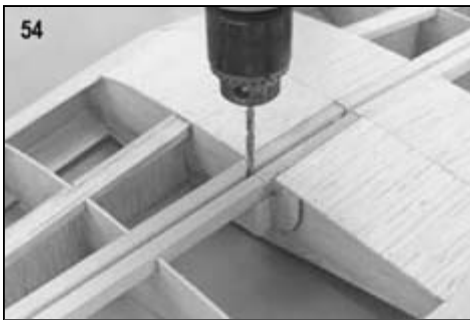
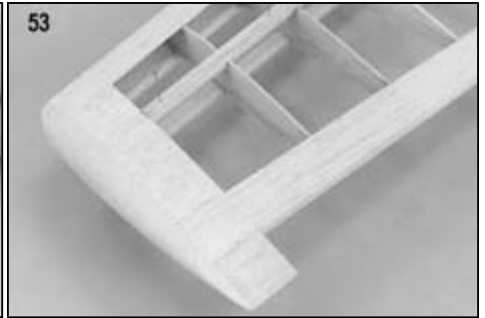
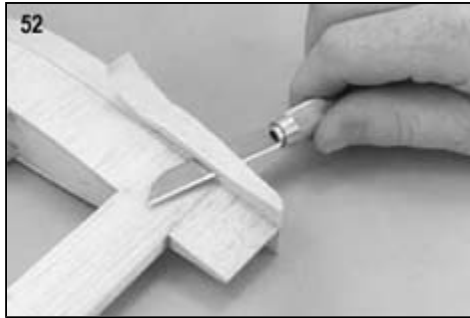

56. Fill in the landing gear block groove in the center section with scrap balsa.

57. a. Cap the top of each spar with a strip of 1/16"x1/4" balsa.  
b. Cap the top of each rib with 1/16"x1/4" balsa.

58. Remove the top center-section sheeting over the trailing edge for installation of the WP plywood parts.

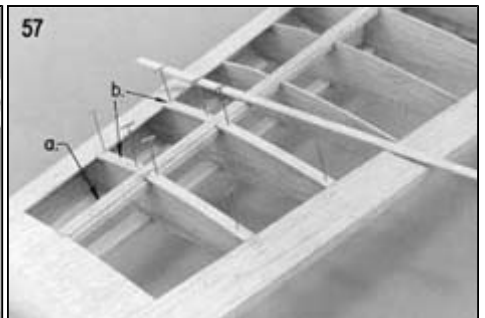
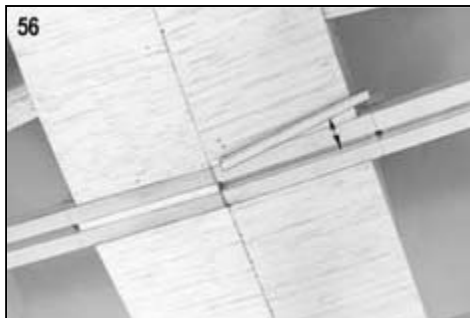

59. Position the WP part so that it is in line with the top surface of the wing. Use a ruler to check this.

60. Glue one of the WP pieces in place.



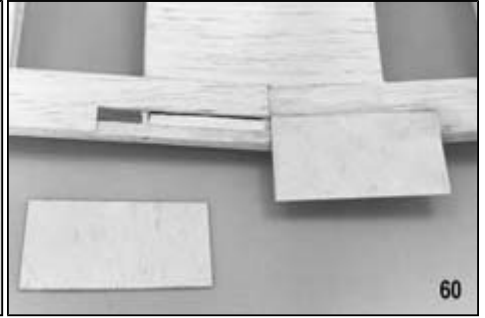
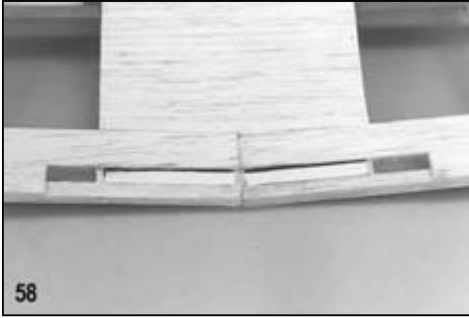

61. Add the second WP part.

62. Turn the wing over and drill holes to pass the aileron horns.

NOTE: Keep the horns close together in the middle so that the aileron pushrods will have no trouble clearing the two servos mounted on each side of the fuselage. Remember that there will be two nylon fittings on the horns. You may need to bend the horns slightly for parallel position.

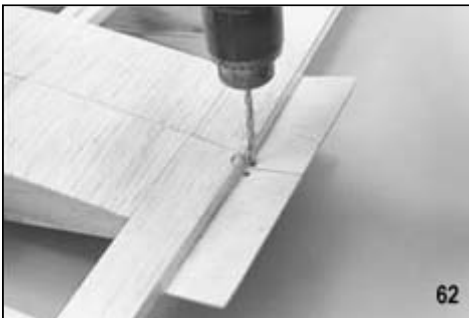
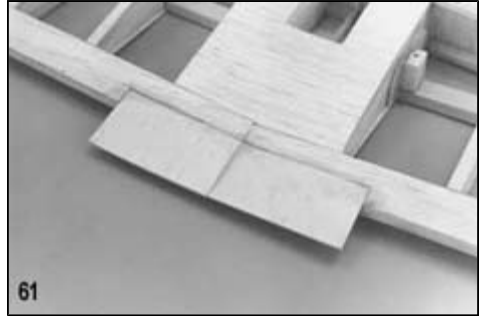

- 63.
- Pin the horns in position so that they line up with the center of the wing trailing edge.
  - Glue the tubing to the wing and WP.

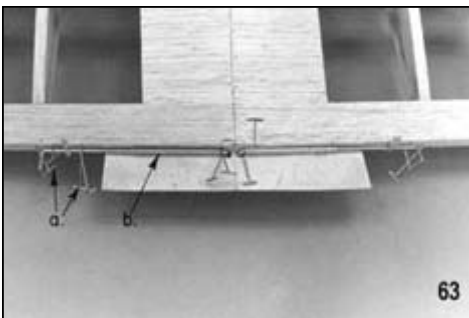

- 64.
- Cut pieces of 1-32" x 1" trailing edge stock.
  - Carve out the fronts of the pieces to pass the tubing and horn.
  - Glue them to WP and the wing. Be careful not to get glue in the tubing.

## HINGES

Using a No.11 X-Acto blade (or similar) cut a slot approximately 1/2" in depth and slightly wider than the hinge. After all slots have been cut, insert an Easy Hinge halfway into each slot in one of the pieces to be hinged. Then carefully slide the matching model part onto the other half of the hinges. You'll find it easiest to slide the part onto the hinges at an angle, one hinge at a time.

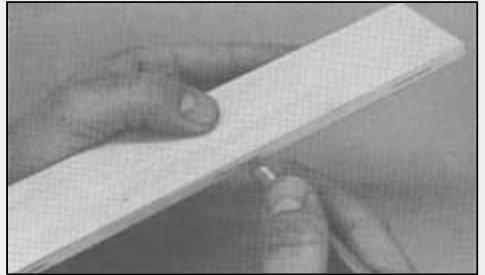

At this point the surface to be hinged is attached but not glued. Align the two surfaces and adjust the gap between them as required. For best control response, the gap should be as small as possible but big enough to allow the control surface to move to the maximum deflection that you will require.

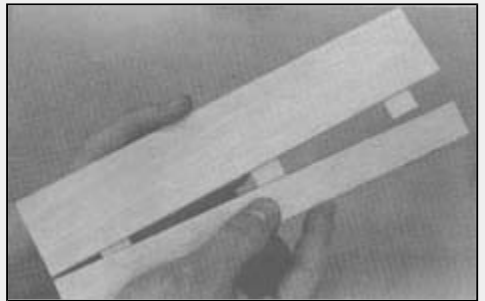

Place three or four drops of any brand of cyanoacrylate adhesive (thinnest variety) directly onto the Easy Hinge in the gap. You will notice that the glue is quickly wicked into the slot as it penetrates both the wood and the hinge. Continue this process, gluing the same side of all of the hinges. Then turn the surfaces over and repeat the gluing process on the other side of each hinge. After the glue has cured, approximately three minutes, the joint can be flexed. You may notice a slight stiffness in the joint. This can be eliminated by flexing the surface to full deflection each direction a couple of dozen times. Don't worry about shortening the life of the hinge as they are almost indestructible.

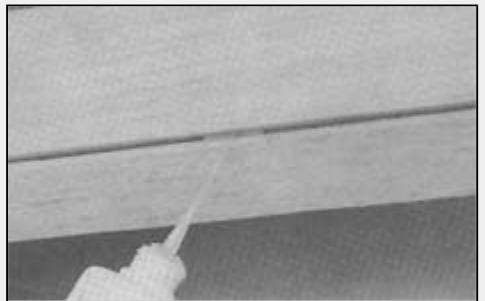

65. Trim down the trailing edge stock as required to match the wing contour.

66. Drill a hole in the aileron to accept the horn.

- 67.
- Cut a slot in the end of the aileron in which the horn wire will be inset.
  - Cut slots in the ailerons and wing for the hinges.  
NOTE: At this point it is best to cover both the wing and the ailerons before gluing the ailerons to the wing. This is particularly advisable in the case of plastic film covering so that access to the edges of the parts is open to the iron.
  - Glue the hinges into the ailerons and allow the glue to set up.
  - Glue the aileron hinges into the wing and simultaneously glue the aileron horn to the aileron.
  - Check positioning and clearance carefully before the glue sets, making sure the aileron is correctly located.

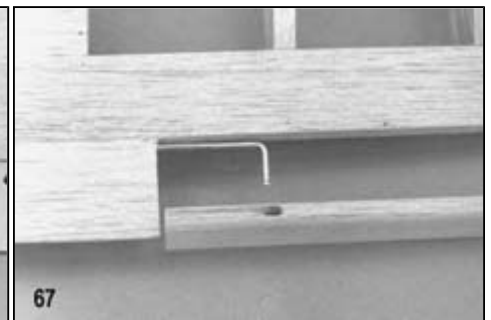
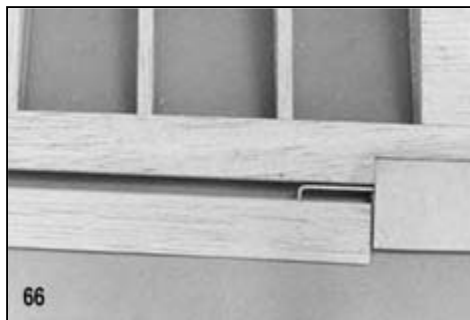
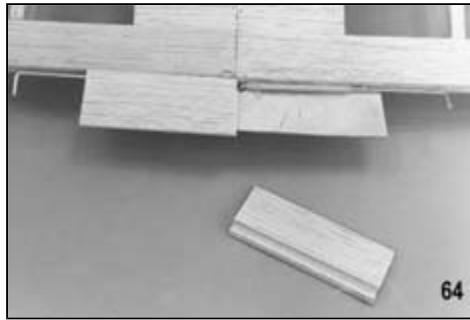

### Aileron Horns

Turn self-threading nylon connectors onto the wire aileron homes.  
Raise or lower them to adjust the amount of aileron movement.

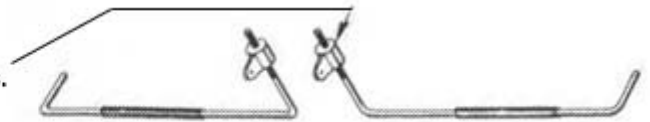

## FIREWALL ASSEMBLY

- 68.
- Smooth and even F-1A and F1-B with the sandpaper block.
  - Glue them together with epoxy glue, as shown in the drawing, to make a firewall. If they should be warped, clamp them together with "C" clamps or put the assembly in a vise while the glue is setting.
  - Mark the vertical and horizontal datum lines.
- 69.
- Place the motor you will use on the firewall or measure the mounting width required.
  - Draw accurate guidelines, centered on the vertical line for the motor mounts.
- 70.
- Put a mark on the sides of the mounts, lined up with the top of the mounts, so that they may be accurately located on the firewall horizontal line.
  - Mark the mount holes on the firewall.

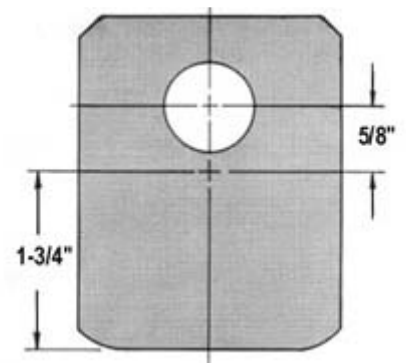

71. NOTE: Read "Tips On Tanks" over before cutting out the tank hole.

- Locate the center of the tank cap hole and draw a 7/8" circle on the wood.
- Drill a series of holes on the inside of the circle.

72. a. Break out the wood and sand the edges smooth with sandpaper wrapped around the dowel.

73. a. Drill out the motor mount holes with a 7/64" bit to pass the 4-40 bolts.  
b. Position the nylon nose gear bearing on the firewall, punch the holes with an ice pick or awl and drill out with a 7/64" bit to pass the 4-40 bolts.  
c. Turn the firewall over and drill out the backs of the 7/64" nosegear bearing holes with a 9/64" bit to take the shanks of the 4-40 blind nuts. To complete the holes, take a modeling knife and round off the edges on the back of the firewall so that the rounded off part of the blind nut will fit down into the hole when it is pulled tight against the firewall.  
d. Drill out the backs of the motor mount holes in the same way.

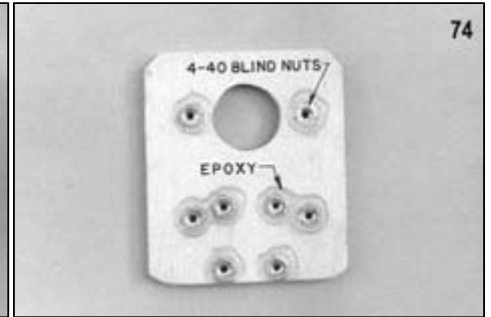
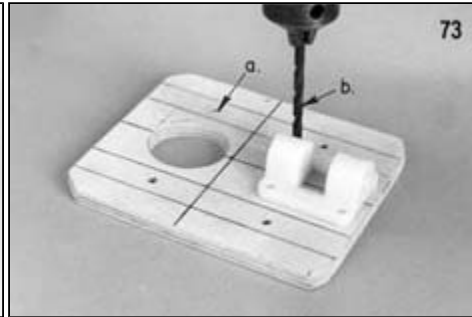
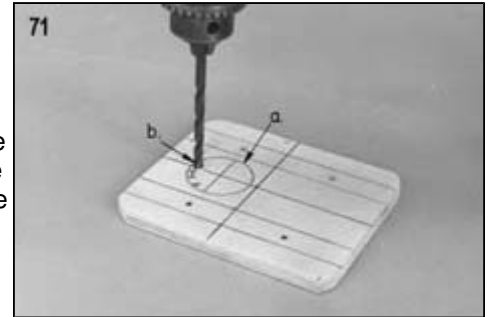

74. Be sure and epoxy the blind nuts to the back of the firewall so that they will not come out later when it may be necessary to take off the mounts. Work some under the nuts but don't get epoxy into the threads of the bolts. Pull the blind nut points tight into the wood with the bolts before the glue sets up. With the mounts and nose gear bracket in place, cut off the mounting bolts for both flush with the face of the blind nuts on the back of the firewall. This is to prevent any chance of the bolt ends puncturing the tank or rubbing on the batteries.

75. a. Put on the spinner backplate that will be used on the motor. (Note: some backplates have a recess in the back as does this Goldberg spinner used on the prototype Kobra. This is why the measurement must be taken from the spinner backplate itself and not the prop drive washer on the motor.)  
b. Position the motor on the mounts so the spinner backplate will be 3-1/4" from the face of the firewall. It is handy to tack the motor in position with some spots of epoxy, brought up over the edge of the engine to grip it good or put a strip of double-faced masking tape between the engine and the mounts. This will keep it from slipping during the next step.

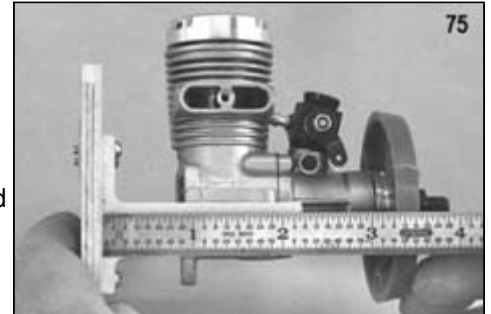

76. With a punch or sharpened piece of 3/32" wire, center punch the motor mounting bolts. (Hint: If you are not used to doing this sort of job, don't try to punch and drill all four holes at once. Punch and drill only one hole. Then put the motor back on the mounts, secured by the first bolt. Punch and drill a 2nd hole, repeat the procedure, then a third hole, etc. With this process you are much less likely to make a drilling mistake that will ruin the mounts.) Drilling our mounts will not be a problem if a good quality high speed drill bit is used, operated at neither too fast or too slow a speed, lubricated and with moderate pressure.



**IMPORTANT:** If you are going to tap a hole in the mounts for mounting the engine, you will need a No.43 drill. Tap out this hole with a 4-40 tap. Be very careful, aluminum galls the tap easily, it may jam and break the tap. Back it out frequently and clean the fragments out of the tap threads. Use a special aluminum tapping fluid or kerosene to lubricate.

SIGSH104 4-40 x 1/2 Socket Head Bolts are recommended for mounting the motor. They are not furnished because some builders may not have a tap. If you do not have access to a tap, then drill a 7/64" hole and use 4-40 bolts long enough to go completely through the mount. Fasten them with nuts and lock washers. It helps with this method to file a flat place on the tapered bottom of the mount so the nut and washer will seat squarely.

## TIPS ON TANKS

**IMPORTANT:** To prevent fuel spray from staining the canopy, run the tank vent line out of the bottom of the cowling. Fill the tank through the muffler pressure line or needle valve line.

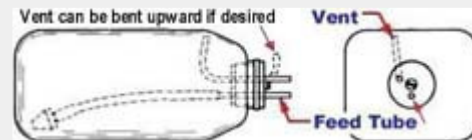

We occasionally receive suggestions from builders that a removable hatch be designed into the model for access to the gas tank. Our opinion is this is not the best method in most cases. The hatch opening makes the nose weaker and there is no good way to keep oil leaking in around the hatch. A method of fastening has to be built into the fuselage to hold a hatch in place.



Modern plastic tanks are virtually indestructible under normal use and bursting or cracking is almost unknown. If you use Sig Heat Proof Silicone tubing (which will not harden or deteriorate in fuel) in the plastic tank, the tank will seldom have to be removed. We have models in which tank has been installed for three or four years without ever needing removal. So it is quite practical to put the tank in semi-permanently. Check the models at a contest - you'll find that the majority have sealed noses, as does this kit.

### Read this before you drill the 7/8" hole in the firewall.

Some fliers prefer not to bring the tank cap through the firewall as is shown in the construction sequence in these instructions. Instead they drill two holes for the vent tubes only and make the vent tubes long enough to extend through the firewall. This method requires little sealing but it is more difficult to install and remove the tank. The best way to manage this is to feed long pieces of fuel line through the holes and attach them to the tank in the cabin area. Steer the tank into the nose as the tubes are pulled back through the holes. If you are undecided as to which method you should use, our advice is that large hole installation shown in the construction pictures is the best for beginners.

Put scrap wood supports under and at the back of the tank. The front is supported by the 1/4" hole in the firewall. Seal the tank cap in the hole with G.E. Silicone Bathtub Seal (available at hardware stores) or Devcon Seal-It. Put an oil-proof finish on the firewall and in the hole before sealing the tank cap. Get some of the sealer on the sides of the hole and also put a bead over the edge of the cap at the front. Should you need to remove the tank, break out the scrap wood supports in the rear and push out the silicon rubber seal around the front cap. Reach into the fuselage and guide the tank outside.

Some builders, after putting their receiver battery in a plastic sack, taping it shut, wrapping it in a foam rubber package and stuffing it into the nose under the tank, then stuff paper toweling or foam rubber in to fill the nose compartment and keep everything firmly in place.

After installation, put fuel tubing on the vent tube and run it to the outside of the cowling on the bottom, so that fuel overflow is not blown over the wing-fuselage joint, where it may leak into the fuselage. The best way to fill the tank is to take off the fuel line to the needle valve and pump the fuel in there until it runs out the vent. Be sure and use a filter on your fuel supply can, and it is a good idea to have a filter between the tank and the needle valve also.



### Pressure Feed

If the engine you are using is equipped with a muffler pressure tap, make use of it for a more even fuel feed and reliable operation. The hookup for pressure feed is shown in the picture. To fill the tank, remove the fuel line from the engine and pump the fuel in. When the tank is full, it will overflow through the muffler pressure line. Use transparent or translucent fuel line so you can see the fuel starting to overflow when the tank is full. Should some fuel happen to get in the muffler, drain it out before starting the engine. Do not try to fill the tank in reverse from the pressure line, the tank will not fill properly and fuel may be forced into the engine.

## FUSELAGE CONSTRUCTION

The nose was designed to accommodate average engines in the recommended range. Certain engines of bulky configuration or long crank cases may be a little crowded. In this case it would help the fit to cut the fuselage sides out a bit longer at the front and also part FX. Check the fit of your engine before beginning.

77. a. Pin and glue the first top strip of 1/4" triangular stock in place on the fuselage side sheet.  
b. Pin and glue the first bottom strip in place.

NOTE: If the fuselage sides are bowed or warped, it will not be a problem. Pinning them down to a flat building board and gluing on the structure will flatten them out.

78. a. Pin and glue on the second top strip  
b. Pin and glue on the third top strip.  
c. Pin and glue on the second bottom strip.

79. a. Cut a piece of 3/16" sq. from the scrap remaining from the wing trailing edge to fit on the triangular stock.

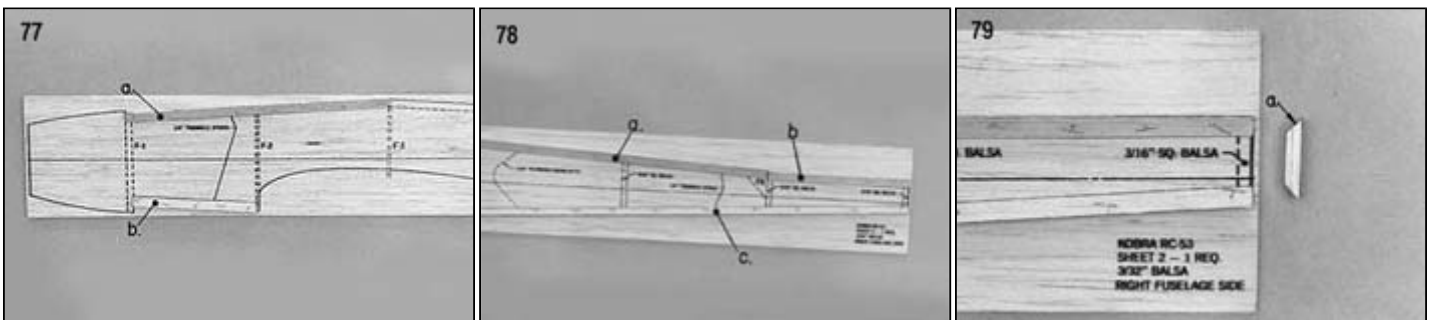

80. a. Glue the 79a piece in place.  
b. Do the same for the next upright.  
c. Bevel the upper edge of FA to fit against the triangular stock and glue it on.

81. If the 1/32" plywood doubler FD does not fit down against the fuselage side evenly, sand or bevel the edges until it does. (Triangular balsa stock varies in dimension slightly so it is not possible to die-cut the doubler to fit perfectly in every case without a bit of fitting.)

82. Glue FD in place on the fuselage side.

CAUTION: Epoxy or gap-filling cyanoacrylate glue is recommended for FN. Water base glues such as Sig-Bond, Tite Bond, Elmer's etc. may cause curling because of the large area being glued. Spread a thin film or epoxy with a paddle. Don't use a large amount of epoxy glue - it will add weight to the model.

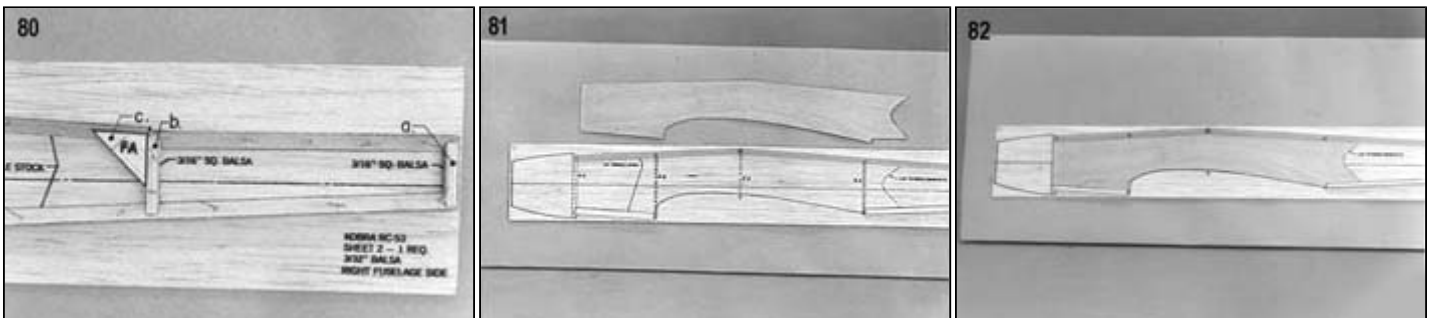

NOTE: Look ahead to picture 90. You will see pieces of 3/4" triangular stock being glued on the back of the firewall. These must be cut to fit against the 1/4" triangular stock on the fuselage sides. Do this now, on the sides, while it is easy, before they are joined together. Lay the pieces aside for use at picture 90.

83. Cut the fuselage sides from the sheet with a modeling knife. Don't cut too close, leave a bit for sanding. Cutting too close can result in too deep a cut that is harder to fix than taking down the side a little with the sanding block.

84. a. A small gap remains at the end of the front bottom triangular stock. Cut a small piece of 1/16" balsa sheet, thinned down to 1/32" thickness to fit the gap.  
 b. Glue it in place.
85. Pin the two fuselage sides together, outside to outside and match them by sanding as required to make them exact duplicates

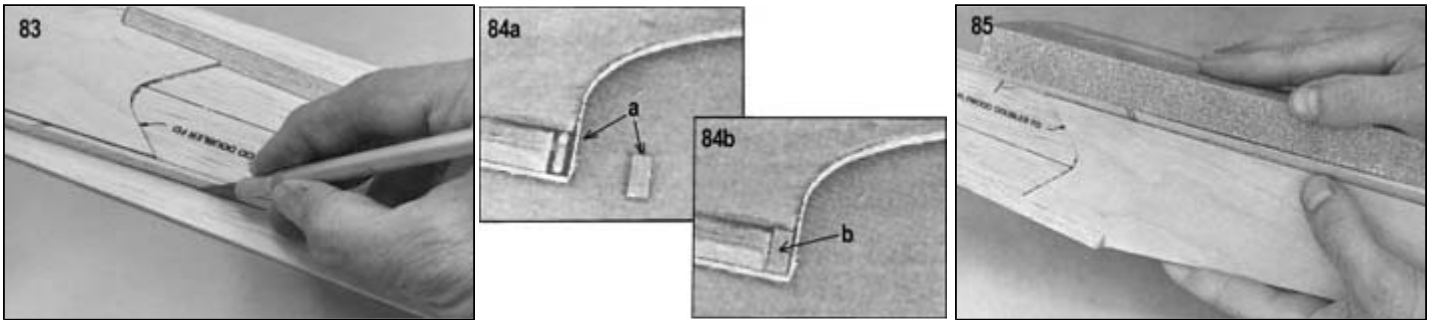

86. a. Place the top view fuselage plan on the building board so that the cowl notch at the front of the fuselage is just over the edge. (Or you can put the entire plan on the building board and put scrap 3/32" shims under the fuselage sides.)  
 b. Pin the sides in place on the plan, top side down against the plan.
87. a. Glue F-3 in place. Use a triangle to insure squareness. Pull sides together with tape. Minor adjustment in pinning down may also be required.
88. a. Glue F-2 in place.  
 NOTE: While we put on the dowel doubler and drilled the dowel hole later on in the sequence, you may wish to do it now, before gluing F-2 into the fuselage. In this case, look ahead to pictures 98a and 98b.

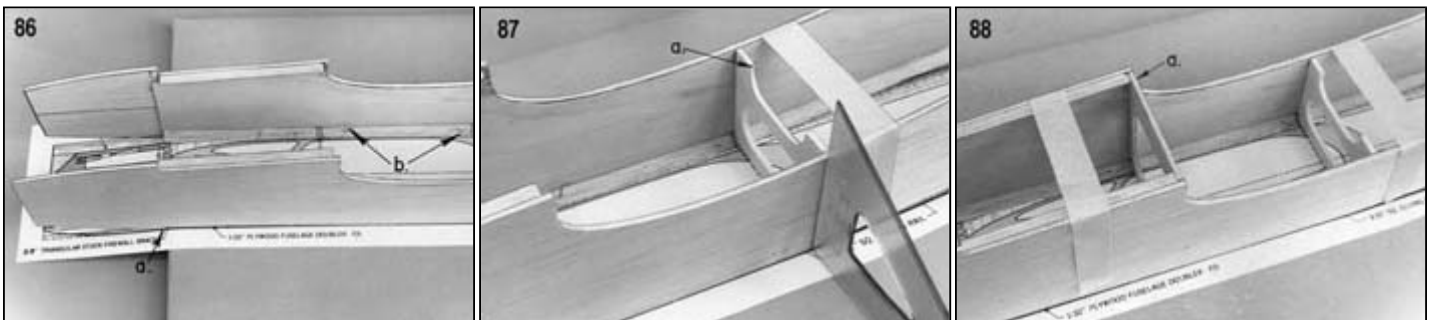

89. a. Glue the F-1 firewall assembly in place.
90. a. Glue pieces of 3/4" triangular stock to the back of F-1.  
 b. Cut away the stock to clear the blind nuts.



91. Move the stabilizer mount portion of the fuselage assembly and plan off the building board until the sides will sit down on the board on the fuselage top. Pin down securely at F-3. Use vertical sided weights to pull the sides together at the rear and pin where necessary to hold the sides to the correct plan shape.



92. a. Glue F-4 in place.
93. a. Cut a piece of 3/32" cross-grain sheet balsa and glue it on the rear of the fuselage.
94. a. Cut a piece of 3/32" sheet, with beveled edges to fit against the triangular stock and glue it against the back of F-4.

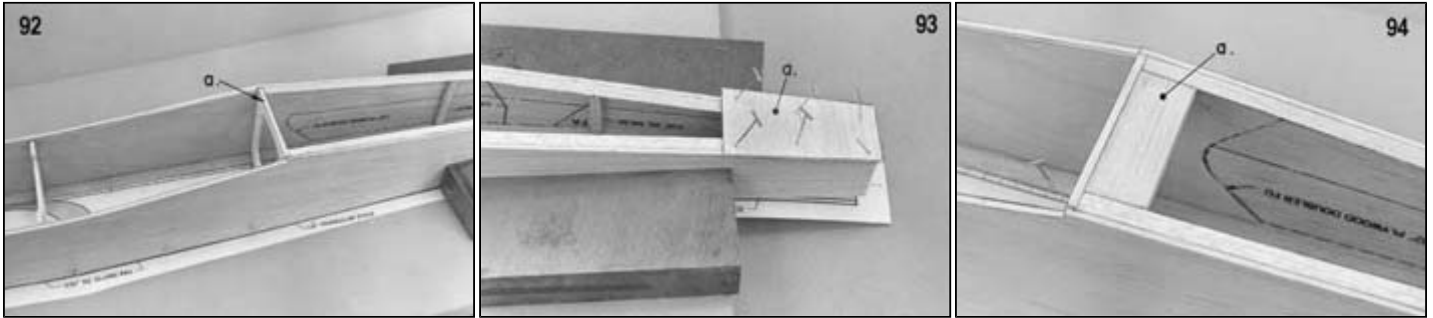

95. Complete the bottom rear fuselage planking by gluing on pieces of 3/32" sheet balsa. Allow to dry before removing. This method of construction prevents the fuselage from bowing or twisting after being unpinned, even if the wood on one fuselage side is harder than the other.

96. Glue FX cowl pieces on the inside of the fuselage front.

STOP: Before proceeding go back and reread the "Tips On Tanks" section and install the tank hardware in the tank.

97.
  - a. Fit the tank into the compartment.
  - b. Glue scrap balsa blocks to each side of the fuselage.
  - c. Don't get the blocks too tight - just enough to keep the tank from rattling around. The tank will need to be easily removable after the top and bottom of the fuselage are closed up, so make certain now that there is no obstacle to doing this. Note particularly the "bubble" on Sullivan tanks, which must clear the side blocks. The bubble is not used on the Kobra because the whole side of the tank is placed horizontal. The tank will work fine without the "bubble" being in use.

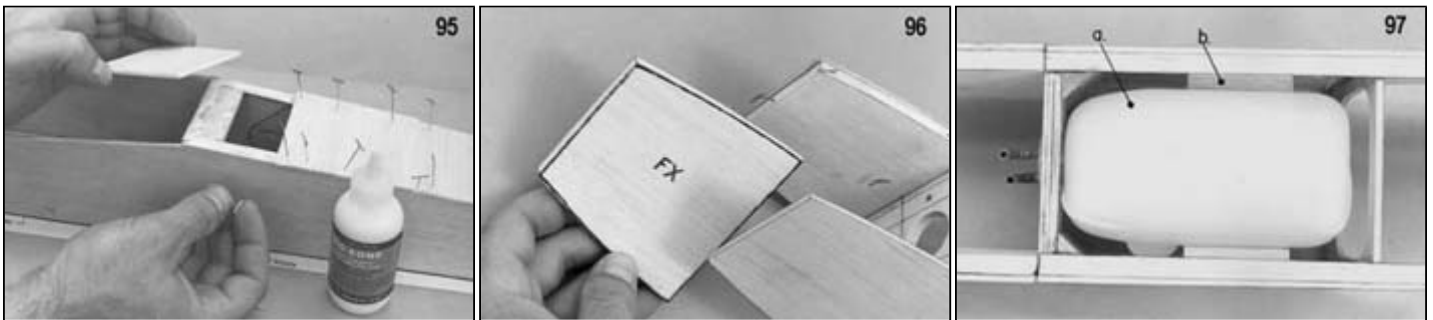

98.
  - a. Glue F-2S, a 3/32" plywood square to F-2.
  - b. Mark and drill the dowel hole. Before proceeding, you will need the completed wing.

99.
  - a. Set the wing in the fuselage saddle. If it does not fit the saddle exactly, sand as required to make it fit. Check to see that the fuselage sits squarely on the wing.
  - b. Hold the wing in position and mark the dowel holes in the wing by punching through the hole in F-2 with a 1/4" drill, a piece of tubing or a rod.
  - c. Drill the holes in the wing out oversize - about 9/32" diameter - to allow some "wobble" room during final positioning and gluing in of the dowel.
  - d. Put a piece of wax paper over the face of F-2 and insert the dowel through the paper into F-2.
  - e. Coat the hole in the wing with Kwik-Set Glue. Don't overdo the amount of glue.
  - f. Put the wing in place and secure it in position with masking tape. Hold the fuselage vertically to keep the glue from running out of the dowel hole. Allow the glue to set up firm, not fully cure, just in case it may have stuck the wing to the fuselage in some leaky spot. Remove the wing. If the dowel hole is not completely filled with glue, fill it. If necessary, now that the dowel is set in place, you can cut away the wood around it to provide room for filling any remaining crack with glue.

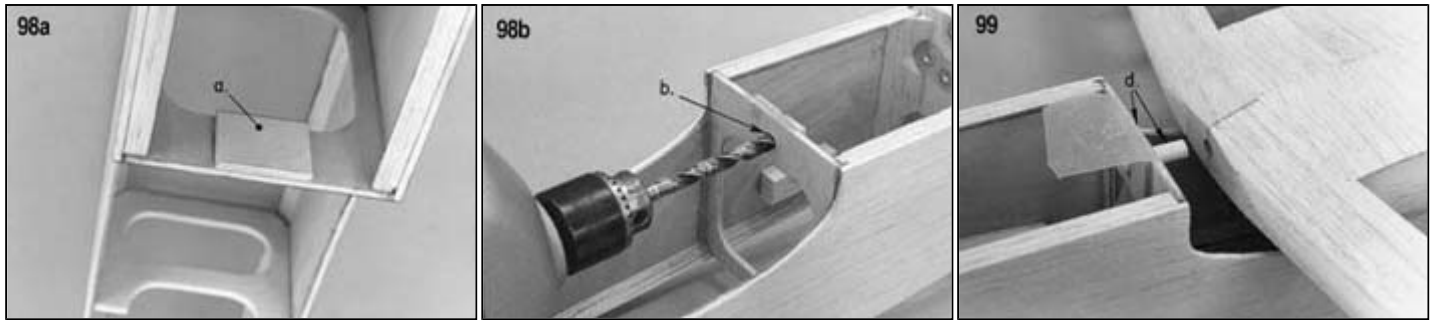

100. a. Put the wing on the fuselage again with a piece of wax paper between it and the fuselage at the back.  
 b. Epoxy the wing bolt anchor blocks in place against the fuselage sides.

101. a. Locate the position of the wing bolt anchor blocks on the bottom of the wing. (Remember that the wing bolt holes are drilled at an angle so that the heads of the bolts will end up flush with the surface of the bottom of the wing.)  
 b. Drill a hole through the wing and on through the anchor blocks with a no.21 drill. ( $5/32$ " is the nearest inch size equivalent.)

Brace anchor blocks with pieces of scrap  $1/4$ " triangular stock balsa.

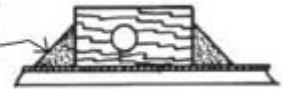

102. a. Run a 10-32 tap through the hole to cut threads in the wing bolt anchor blocks.  
 b. Drill out the holes in the wing with a  $3/16$ " diameter drill to pass the nylon wing bolts.

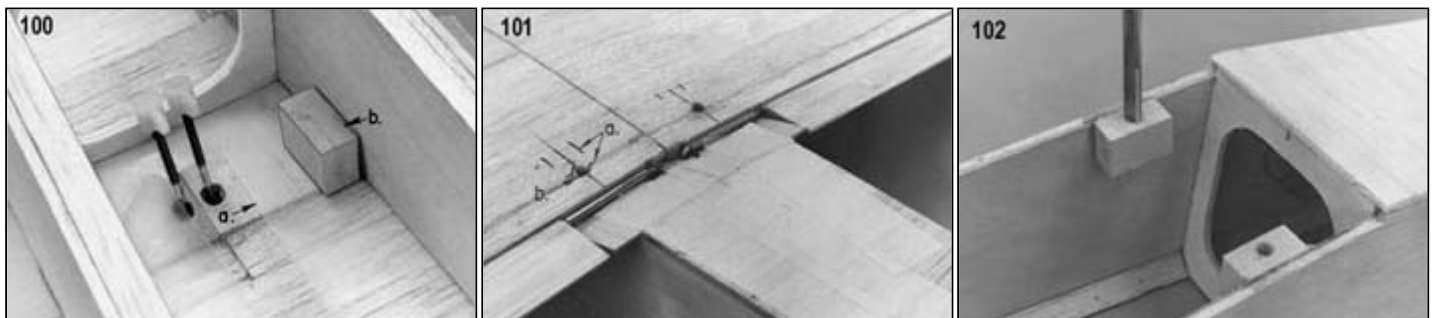

103. We did not find it necessary to reinforce the wing bottom around the bolt holes, since the silked and doped finish was sufficient to harden the surface so the bolt heads would not sink into the wing. With plastic film covering, you may want to glue a plastic square from the landing gear cover scrap to the balsa for the bolt head to seat against.

**NOTE:**

Before proceeding, give some thought to the radio installation you will be using. The Kobra is not a large model with space to spare. But there will be no problem getting any standard set in the model if the installation is planned properly. The basic requirement is to put the rudder and elevator on the fuselage walls toward the back of the compartment. This leaves space between them for unhindered passage of the aileron pushrods and horns when the wing is on. Don't worry about putting this much weight that far back, the balance works out okay this way. In fact, the battery in the prototypes was mounted in the fuselage over the wing, not in the nose. Place the motor control servo just ahead of F-3, also on the wall of the fuselage. This leaves considerable remaining space for the receiver and battery. (The first prototype carried a big 7 channel receiver easily.) The plastic servo mounts were fastened to the fuselage sides with double-sided foam tape. It so happened that no Kraft mounts of the kind needed were on hand when the installation in the first prototype (the F-16) was done but it was found that Futaba "H" servo mounts fit the Kraft 14 servos fine, so they were used. Also, read the section on "Radio Hookup" included in these instructions.

104. The engine and nose wheel pushrods should be installed now while access to the fuselage interior is easy. Use an extra length drill to make the holes for the nylon outer tubing. Or, put a point with a notch on it on a long piece of music wire and use that for a bit.

105. This shows the nose wheel pushrod running to the rudder servo.



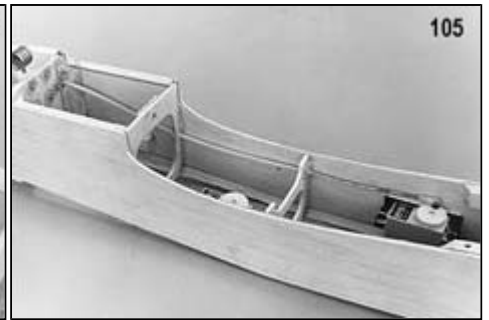
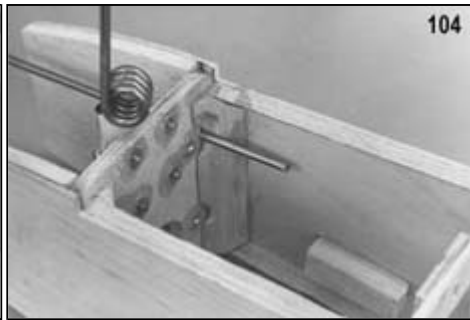
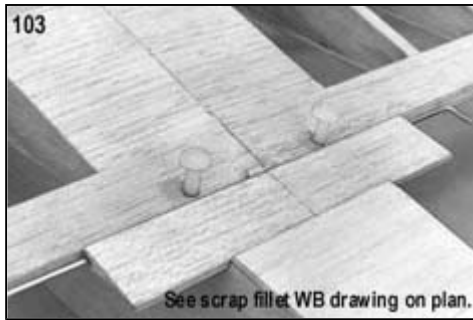

## NOSE GEAR INSTALLATION

The wheel collar suggested as optional for the nose gear is not furnished. File or grind a notch in the collar so it will fit down on the coil farther. The collar permits altering the height of the nose gear slightly if desired. Don't try to make large adjustments in nose wheel height with the wheel collar because the landing gear is more easily bent on a hard landing if the coil spring is located very far below the nylon nosewheel bracket. Large adjustments should be made by changing the wheel size.

106. The front of the model with hookup of the nosewheel pushrod to a Goldberg PC-1 or Du-Bro 121 fitting on the steering arm.

107. Futaba servo on an "H" mount for the motor control pushrod.

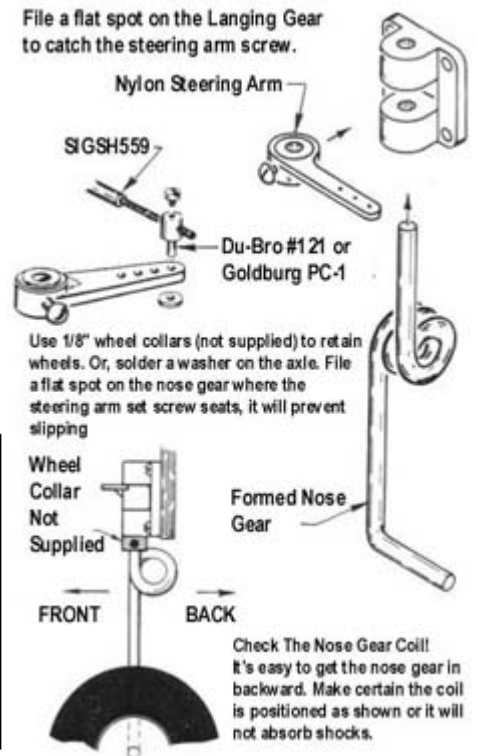
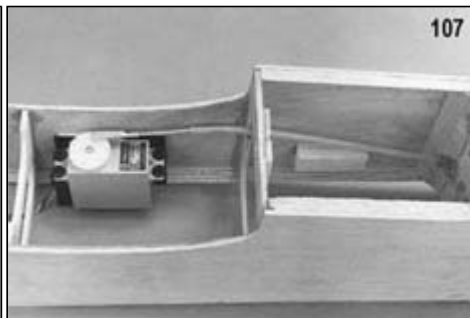

108. Sheet the top of the fuselage with pieces of 3/32" balsa, crossgrained.

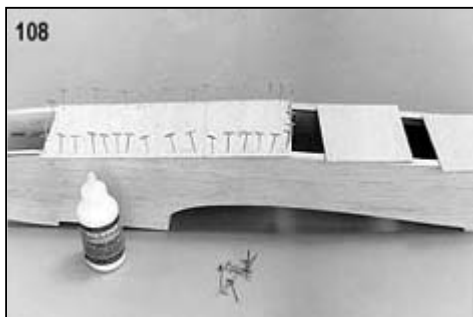

109. Glue the 5/16" sheet bottom on the front of the fuselage. (Note: You may want to resin or otherwise fuel-proof the inside of the nose before doing this. We used Sig Epoxy, warmed to make it thin and easy to brush.)

### Notes On Loops

A true wing will perform perfect loops. A twisted wing will loop obliquely. One wing half being heavier than the other may also affect loop tracking. Side mounted motor may make one side of the model heavier than the other. Put weight in the opposite wing tip until balanced. Should your model snap roll out of the top of a loop, it may snap in the direction of any twist in the wing, but the real reason for snapping is because of a stall. This is probably due to one or more of the following:

- Airspeed too low.
- C.G. too far back.
- Pilot pulls too much elevator, a mistake aggravated by excessive elevator travel which makes the elevator more sensitive. Reduce travel of the elevator and use more care in transmitter stick movement.
- Not enough power, too high a wing loading for the available power or both.

110. Mark the approximate shape of the corners of the model. (See the cross-section drawings on the full-size plan.)

111. Cut the bottom nose block to fit between the FX pieces and carve out the interior to allow easy screwdriver access to the nose wheel steering arm setscrew.

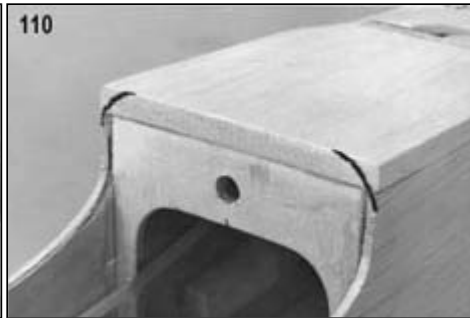
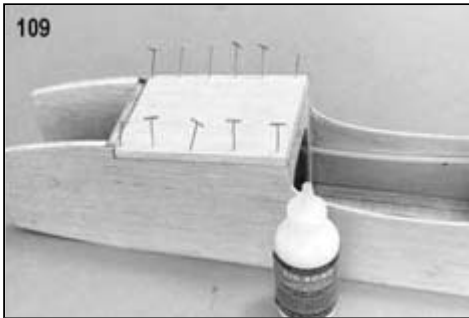

112. Glue pieces of 3/4" triangular stock on the front of the cowl.

113. a. Put the engine in the model with the spinner backplate installed.  
b. Mark around the spinner on the fuselage front.

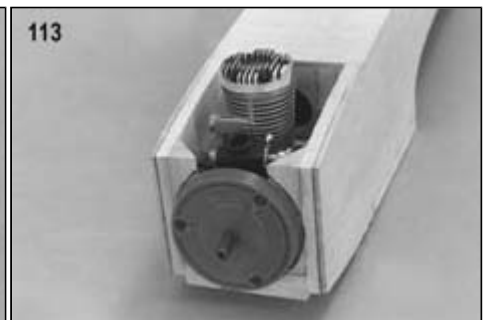
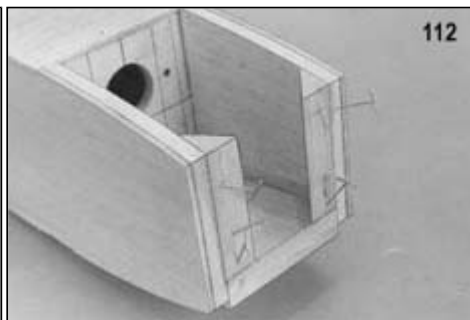
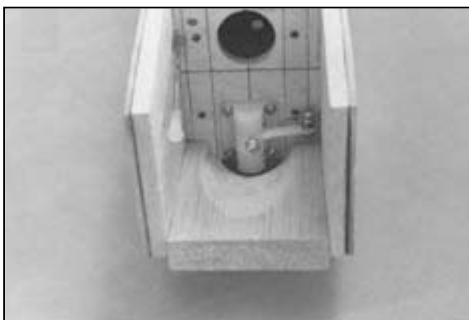

114. Carve the cowl to a pleasing shape. For practicality, this is as far as most builders want to go in cowl in the engine, so as to have easy access to the front end. On the prototypes however, a few more pieces of scrap wood were glued into the cowl on the top to provide some more carving area for a more completely cowed engine. We'll leave it to the individual builders to determine how practical or pretty he/she wants it to be. One observation we'd like to make is that in a small model like the Kobra, there is very little surplus room in the cowl. Changing the throttle linkage or the nosewheel steering is not as easy to do as in a model with a removable cowl. But once adjusted they do not need much attention.



115. Place the canopy and plastic turtle deck on the top of the fuselage. Carefully center and position them and then trace around them with pencil. This will provide guide lines for installation on the 3/32" sq. gluing strips.

**NOTE:**

In reviewing our building sequence for the Kobra, we have decided that it is easier to round and sand the corners of the fuselage before the gluing strips are put on. Use the penciled guide lines to tell where to stop the shaping process. Photo 116 shows the rounded fuselage without the gluing strips in place. Do yours this way and ignore the fact that our fuselage still hasn't been rounded in the next few pictures.

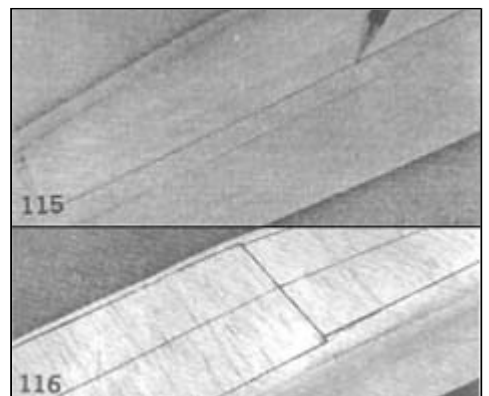

117. Glue the 3/32" sq. gluing strips on, allowing space for the thickness of the plastic parts between the line and the strip.

118. The gluing strips must be trimmed and beveled to fit against the plastic part.

119. Set the parts in place to check how well they seat on the gluing strips and correct as required for good contact.

NOTE: It is recommended that you do not glue the canopy and turtle deck to the fuselage until it is covered and/or at least partially painted. The canopy framing should be painted before the canopy is glued on.

See "Painting The Canopy" further on in these instructions.

Use a Williams Brothers  
1-1/2" Military Pilot  
with part of the base  
cut off.

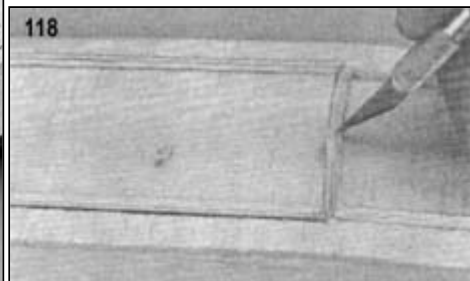
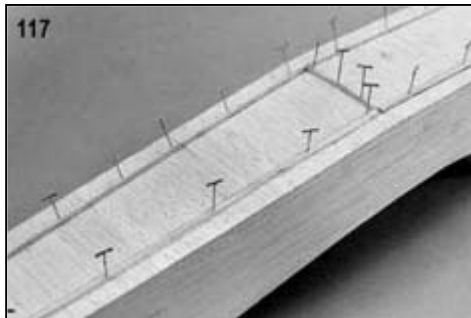

At this point you will need the completed stab and fin assemblies.

120. Pin the stab in place on the rear of the fuselage to check on how square it is with the wing. Correct any misalignment by sanding the fuselage. Do not glue the stabilizer on until later, after it and the fuselage are covered.

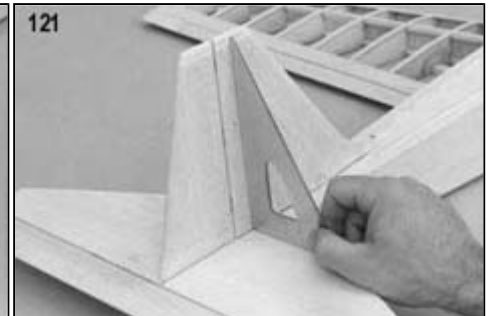
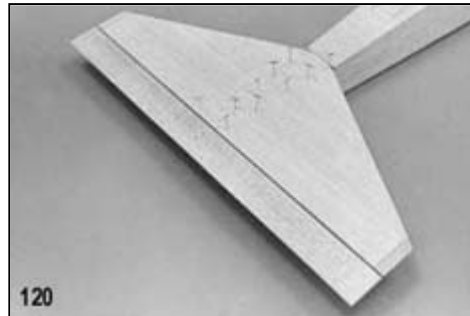

121. Temporarily pin the fin and rudder in place.

122. Using the FT tail fillet patterns, carve the fillet blocks roughly to shape. (See plan for block layout drawing.)

- 123.
- Pin the blocks on each side of the rudder.
  - Use the plastic turtle deck to shape the front of the blocks and the fins so the plastic will fit over them when in place.

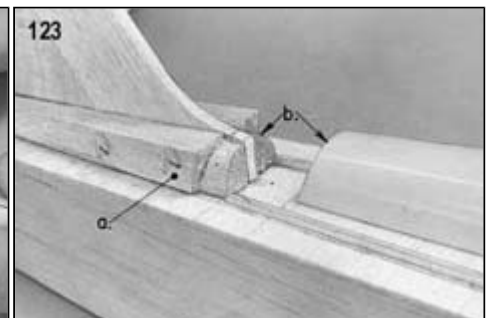

124. Trace the plastic turtle deck shape on the face of the block.

125. Carve the block to shape. Glue it in place later, after the tail and fuselage are both covered and joined.

- 126.
- Put a piece of waxpaper against the front of the fuselage and mount the wing.
  - Carve part WZ to fit on to the contour of the front of the wing and glue on.

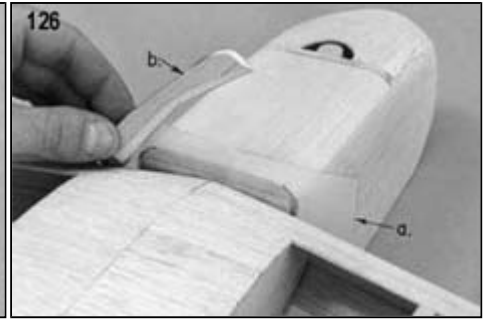
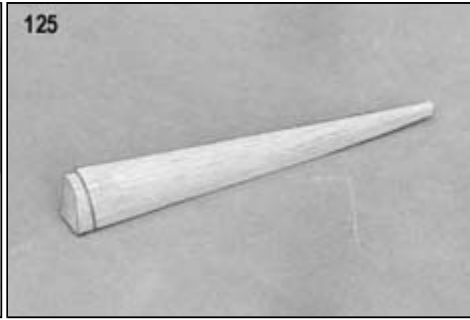

127. a. Cut WX pieces to fit against WZ as shown.

128. a. Remove a strip of planking between the two WX pieces.

129. Insert a piece of 1/16" sheet between the WX pieces and flush with the center section planking.

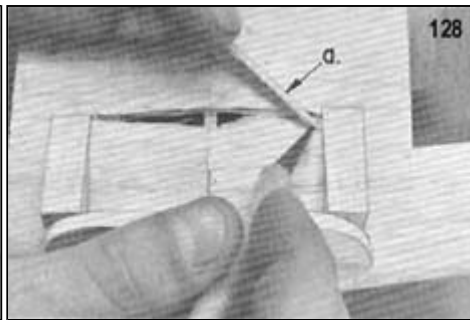

130. Carve the WX pieces to match WZ.

131. Put the wing back on the fuselage and sand the wing cuff to match the fuselage shape.

132. A Futaba "V" type servo tray is shown for the wing.

- a. The landing gear block was used for the rear mounting screws.
- b. A small scrap block of hardwood was glued to the bottom planking for the front mounting screws.

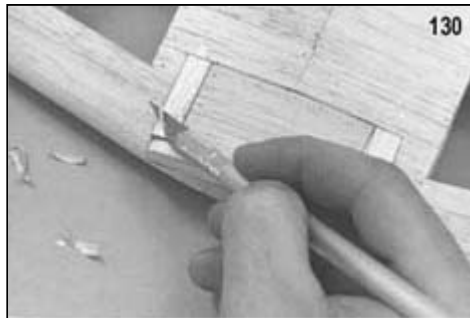

Other types of mounts may require a different placement of hardwood blocks for mounting the aileron servo.

133. A Futaba FP-S16 servo is shown in the wing, hooked to the aileron horns.

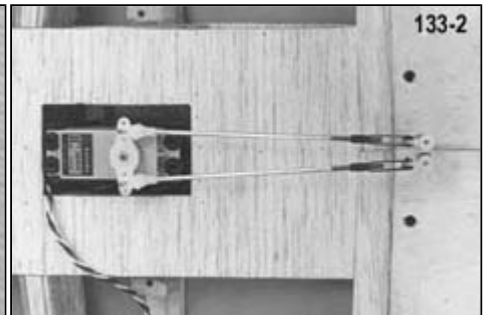
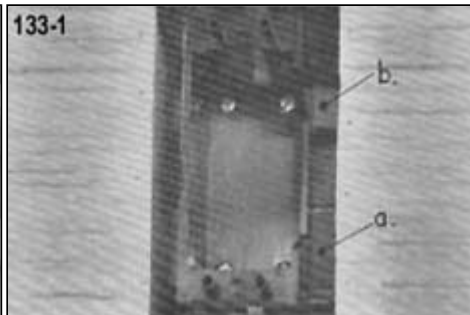

## TAIL SURFACES

You have the option of building the model with either an F-16 styled swept fin or T-38 type of straight fin. The instructions printed on the 3/16" tail printed sheets indicate how to distinguish one tail shape from the other. However, we will show here the pieces for each style of tail. Study them before cutting on the sheet to make certain you are cutting on the right line. You may ask why there are so many parts, when it would be easier to cut the tail from a larger single piece. The reason is to provide a stiffer and more warp resistant tail. The different grain direction of the parts makes the finished surface stronger.

134. These are the F-16 style printed parts. Sand the edges with the sanding block so that a good joint is obtained.

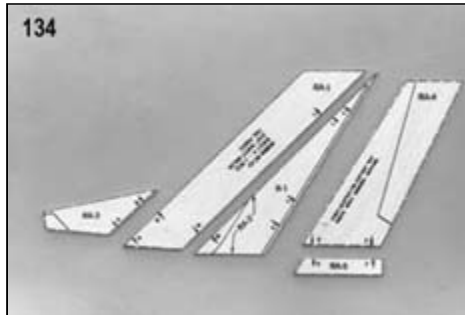

135. a. Glue the parts together on a sheet of wax paper to prevent them from sticking to the board.  
b. Add pieces of 3/16"x3/8" wood to the top of the fin and rudder. (Left over scrap from the wing spars.)

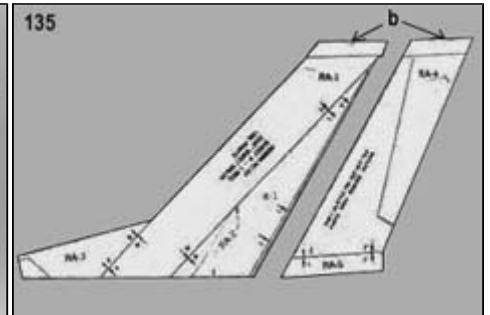

136. These are the T-38 style tail printed parts.

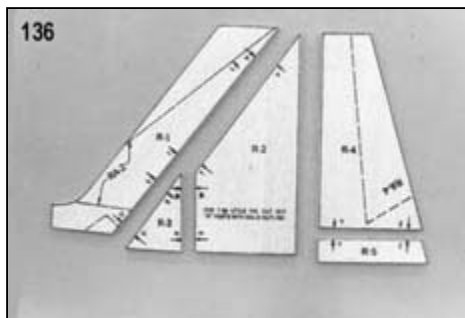

137. a. Glue the parts together.  
b. Add the 3/16"x3/8" scrap tips.

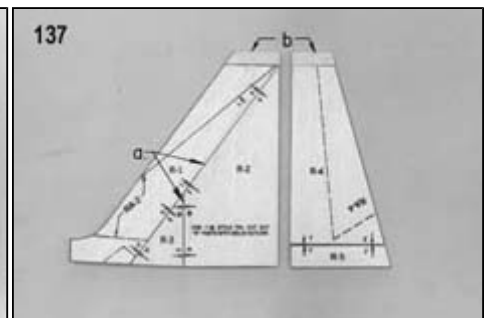

138. Sand the printed lines off the tail parts with the sanding block.

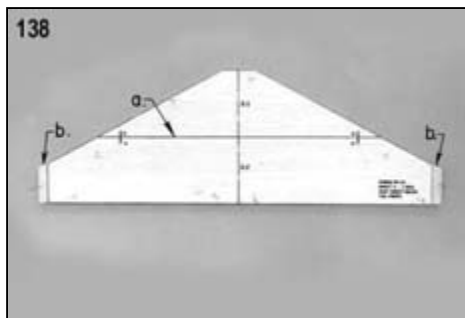

140. Round the leading edges of the fin and stabilizer with a sanding block. Carve and sand the rudder to the cross-section shape shown on the full size plan.



141. The tail surfaces are hinged in the same manner as the ailerons. Cut the slots for the hinges, but do not glue the hinges in until after the tail parts are covered, either with silk or iron-on covering. It is particularly necessary with iron-on covering to cover before assembly so that the iron can be properly applied to the edges. (Some builders like to color dope and/or decorate the parts also before joining.) Join the tail parts together after covering is completed.

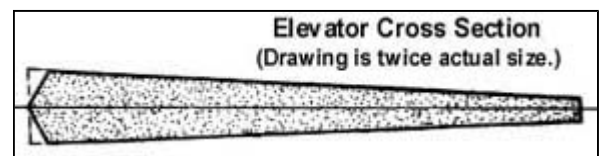

Cover the fuselage before gluing the tail to it, but cut away the covering to expose the bare wood in the spots where the tail is glued on. Always have wood-to-wood joints. Never have covering between the parts. Be sure that the stabilizer is lined up square to the fuselage. Coordinate the fitting of the stab with the fitting of the wing so that they are both aligned properly.



142. If desired a nylon pushrod guide (not furnished) can be used in the pushrod rudder exit slot.

143. The elevator pushrod exits through the rear fuselage opening.

## RADIO EQUIPMENT

### NOTES ON SERVOS

Most servos are standardized as to which direction they move in response to particular transmitter stick movement. Regardless of the direction of movement of the servo, you can adapt to it by moving the pushrod to whatever side of the servo output arm or wheel will give you the pushrod movement direction desired. Sometimes this requires that a pushrod brought down the side of the fuselage has to crossover to the inside of the servo output arm to get the desired direction of pushrod movement.

Some radio manufacturers make available reverse direction servos and often include one or more in an outfit for situations where the opposite direction of pushrod movement without changing servo sides is desired. For example, it is desirable to have the hookup for the pushrods to the nose on the outside of the servo so that the pushrod tubing need not be flexed as far as crossing over to the inside would require. At the same time the pushrods to the tail would be on the inside where there is plenty of room to maneuver it around. Several companies make reversing converters that can be plugged into a servo cord to reverse the direction of movement of a standard servo. But if you do not have a reverse servo it is quite possible to get along without it.

### Which Side For The Rudder Pushrod?

The choice of which side of the fuselage the rudder pushrod will exit from is determined by the position of the throttle control arm on the engine to be used. If it is on the right (most common), use the servo nearest the right side of the fuselage for motor control. Use the servo nearest the left side of the fuselage for the rudder, with the rudder pushrod coming out to the left side of the rudder and the nosewheel steering arm hooked up on the left side of the nose gear bearing.

These drawings are typical plastic servo mounts (Futaba brand shown) of the type recommended for the Kobra

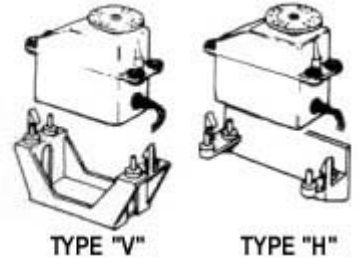

The photos show typical radio installations in the Kobra. There is enough room in the model for just about any standard radio though some of the larger size battery packs may be difficult to get into the nose under the tank. Neither of the prototypes required the battery to be in the nose for proper balance. If you have a large battery pack it may be advisable to finish the model completely except for permanent mounting of the radio components. Set them temporarily in place and test balance the model, shifting the equipment as may be required to achieve the suggested balance point. The best place for the battery out of the nose is either against the back of F-2 or the back of F-3.

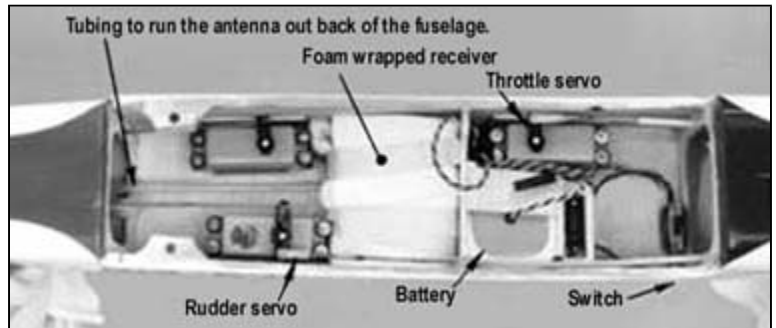

As you can see, it is best to know in advance the radio and motor brand you will be using before you install permanent cable pushrods. Decide on which type of fittings you will use in the case of cable pushrods and have them on hand during construction because the type chosen will affect the location of the pushrod exit holes through the firewall, etc. The balsa pushrods to the rudder and elevator are not limited as to location and can be adapted to any of the types of connectors shown without preliminary planning.

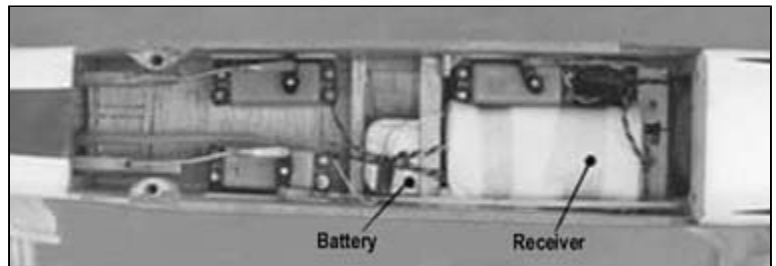

### Pushrods

1/4" square balsa sticks are provided to make the fuselage pushrods that run to the elevator and rudder. Bind the fittings to each end with heavy thread and epoxy glue. Use threaded rods with RC links at the tail end of the pushrods so that trimming adjustments can be quickly made. Straight pieces of 1/16" diameter wire are provided for the other end of the pushrods to allow hookup with the servo arm.

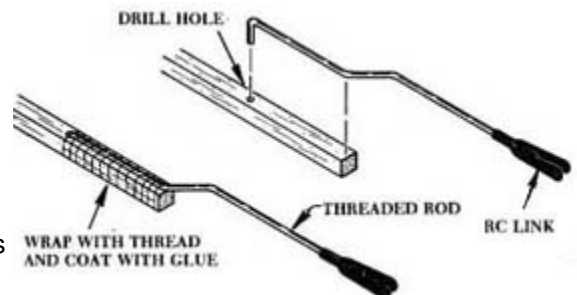

Make the control surface ends of the pushrod first by attaching the RC link rod. Feed through the fuselage, hook the RC link to surface, cut the servo end of the balsa to the exact length needed, measure and install the servo connecting wire end. Some of the variety of detachable pushrod retainers for securing the pushrod wires to the servo that are available are shown here. Or you can make a "Z" bend in the wires to go into the servo. When a "Z" bend is used, the pushrod must be put into the servo outside of the fuselage and then threaded through the fuselage, which is more difficult to manage than the pushrod alone, as is the case when a retainer fitting is used.

## SERVO HOOKUP ACCESSORIES

A wide variety of servo connectors are available for attaching the servo end of each pushrod to its servo output arm. No servo connectors are supplied with this kit because modelers usually develop a personal preference for one type over another and often already have them on hand. Here are photos of a few types.

Sig Solder Clevises (SIGSH527) are dependable and very easy to install. If you are unsure what type of servo connector to use, try solder clevises.

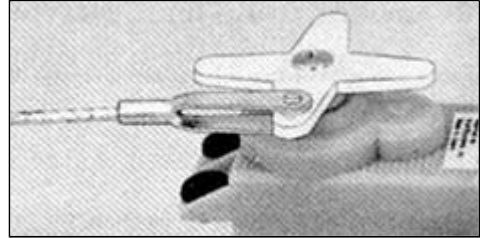

A Sig pushrod connector (SIGSH736) is especially handy for cable end attachment, as on the nosewheel steering arm, but can also be used on servos as shown. They are easily adjustable by loosening the screw and sliding the cable.

Sig Nylon Pushrod Keepers (SIGSH184) or Goldberg Snap'R Keeper can be installed on a wire pushrod after it has been bent 90 deg. and inserted into the servo arm. Not recommended for cable pushrods.

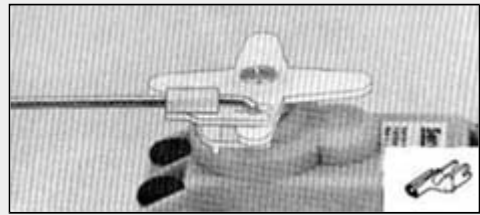
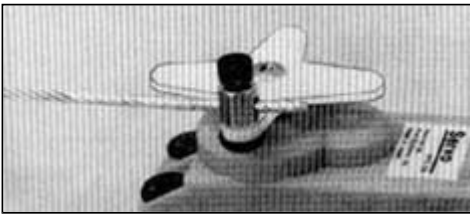

Du-Bro Ball Links, which come in several different types (threaded, bolt-on, rivet etc.), gets the pushrod action up above the control arm so the pushrod can approach from a variety of angles without chance of interfering with the servo center post. It is good for cable pushrods. A fine adjustment can be made by screwing the end in and out.

You won't need any connector for the wire pushrods if you can put a "Z" bend in the end of the wire. It's a little tricky to make a good clean "Z" bend, so practice with some scrap wire before trying it on your good pushrod. Not suitable for cable pushrods.

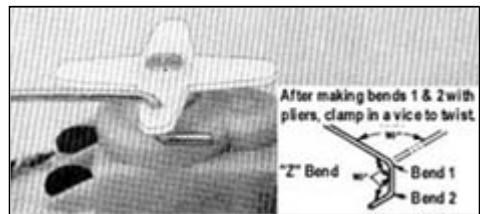
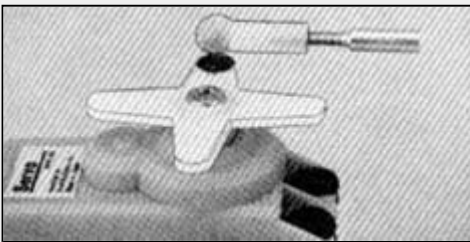

## PREPARING CABLE PUSHRODS

To keep ends of cable from unraveling during handling, tin the end with solder. Use a non-corrosive paste flux (shown here is Kester, available at hardware stores) and rosin core solder. Use a very hot iron to heat the cable and then flow the solder completely through the strands.

When cool, grind or file the end smooth. Taper it down slightly so that it will go into the pushrod fittings and nylon outer tube easily..

After the proper length is arrived at, sweat solder the area to be cut so that it will not unravel while being cut. Cut through the tinned area with a good pair of side-cutting pliers, a cut-off wheel on a motor tool or a file.

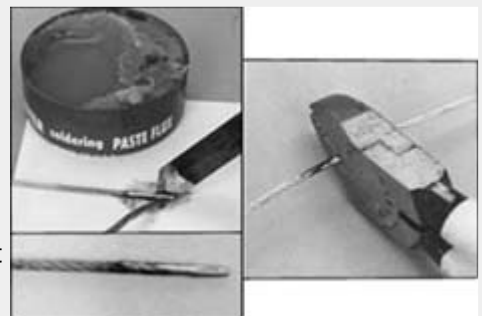

## COVERING AND FINISHING

---

**IMPORTANT:** Don't skip covering the fuselage and tail just because they are solid wood. Painting them without covering first is not enough. They will be much more resistant to splitting and breaking on hard impacts if they are covered with something - Sig Silk, Silkspan, Sig Silray or iron-on covering material.

The manufacturer's directions for applying iron-on coverings are packed with the material. Follow these closely, for different types of covering have different iron-on temperatures and techniques of application.

Whatever kind of covering you desire to use, it will not conceal a rough framework. Sand carefully with fine sandpaper before beginning to cover.

### Finishing The Plastic Top

The plastic top should be sanded to remove the gloss before it is painted. Don't use coarse sandpaper, which can cut deep scratches. These scratches may open up during doping (which softens the plastic) and become noticeable. Instead use something like 220 3-M Tri-M-Ite no load silicon paper to start and polish down with 360 Tri-M-Ite or 400 wet paper before color doping.

The plastic top may be painted with Sig Supercoat Dope. Care should be used not to apply heavy, wet coats of dope. Put on light coats and allow them to dry thoroughly before applying a second coat. A spray gun is a good method of getting a good finish with a minimum amount of dope. Be especially careful with spray cans not to wet the plastic too much. Spray several light dusting coats with adequate drying time allowed. Plastic may also be painted with Sig Plastinamel, K&B Superpoxy, Hobbypoxy or Du Pont Dulux Enamel. Don't use other paints without testing first on scrap plastic.

Do not try to cover the plastic top with plastic film covering. The iron will damage the plastic.

### Covering With Silk, Silkspan, or Silray

Although we refer to silk in the directions, all of these coverings are applied wet in the same manner as follows:

Brush an unthinned or very lightly thinned coat of clear Sig Supercoat or Sig Lite-Coat Dope over all parts of the framework that will contact the covering. When dry, resand with fine sandpaper, to remove any fuzz or raised grain. Brush on a second coat and sand again.

The bottom of the wing is a good place to start covering. Cut a piece of material about 1/2" larger all around than half of the wing, with the grain running lengthwise. (The grain of woven materials runs parallel to the finished bias edge.) Some builders next dip the piece in water and apply it to the wing. I find that the silk sticks together and takes a lot of pulling and smoothing to get it in place so we do it a bit differently as shown in the photo.

Pin the dry covering in place and "paint" the water on with a brush.

Go around the edges, pulling out wrinkles and stretching the material smooth. You need not pull it up drum tight, in fact going to this extreme is not advisable. Just pull out all of the wrinkles. Use pins, if necessary, to hold the silk smooth, though wet silk usually stays in place without too much pinning. We like to fasten one end - in this case the center joint of the wing - pretty firmly with pins so that you can pull against this anchored end in stretching the silk the long way.

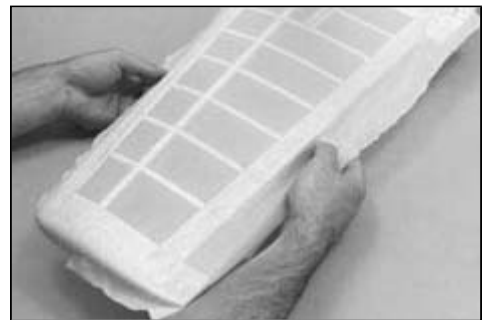
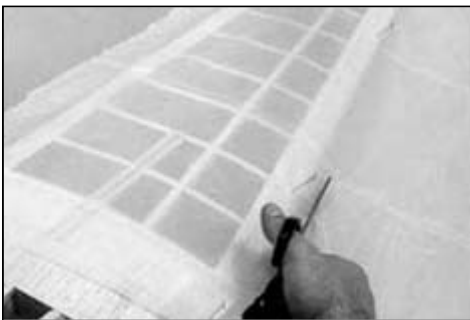

Brush around the outside edge of the stretched silk with clear dope. The dope will soak through the material and adhere to the dope already dried into the framework.

Trim off the edges with a sharp blade. We find that a thin double-edged razor blade is ideal for this, but a single-edged blade does okay and you can't cut your fingers on it. On the bottom, trim off flush with the wing all the way around. Go over any rough areas or places that have not stuck down properly with more dope and press the loose spots down as the dope is drying and getting stickier.



The top half is done in identical fashion except that the silk should be brought down over the edges instead of being trimmed off flush. On the front, lap the silk over the edge of the bottom, over-lapping about 1/8". At the back, bring the material down over the back edge of the trailing edge but do not lap it over the bottom covering.

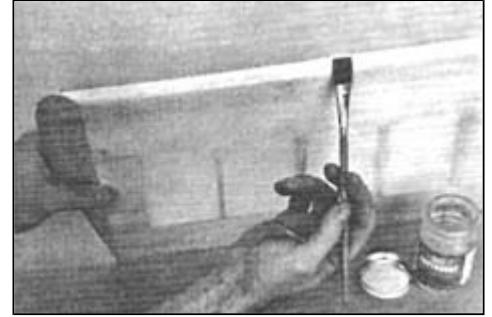
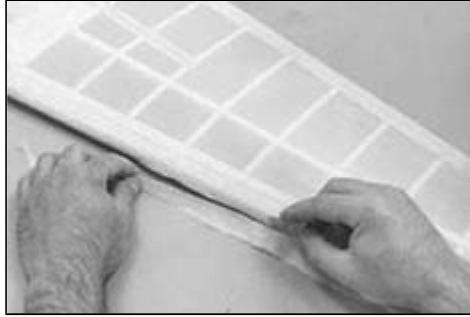
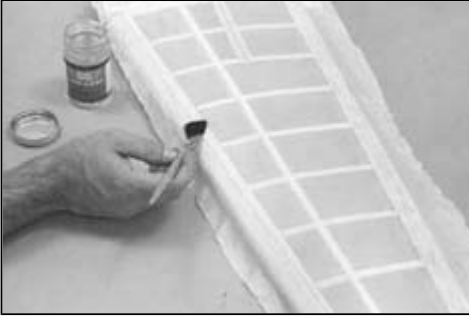

Use the same process on the tail section and fuselage.

Allow the water to dry out of the wood before applying the first full coat of clear dope. On the open framework area of the wing, brush the dope on sparingly. If too much is applied, the dope will be rubbed through the material and will run down the surface on the inside and form a puddle. When these puddles dry, the large amounts of dope solids in them cause more shrinkage than the rest of the covering and a scarred area results. So apply dope very lightly the first time over. A second coat will seal most of the pores of the material and from this point, running through will not be a problem.

Use one or two coats of regular Supercoat clear on the wing to shrink the covering. After that, unless the covering is still not tight and unwrinkled, Sig Lie-Coat low shrink clear dope is recommended to help warping. The solid wood fuselage and tail can have Sig Lite-Coat from the beginning if desired. Sig Supercoat Color Dope has low shrinkage qualities.

A third coat of clear should provide a good base for color. Sand lightly when dry with 220 grit 3-M Tri-M-lite no-load paper. Don't bear down on the edges of the ribs or the silk fibers will be cut through. The color dope may be brushed or sprayed.

Supercoat Color Dope should be thinned with Supercoat Thinner for brushing. This helps prevent brush marks and gives smoother coats. Flow on wet coats and avoid rebrushing back over an area already painted. If brush marks show, you need more thinner. For spraying, thin dope about 50-50. Add more thinner if the dope does not go on evenly.

If high humidity causes the dope to "blush" or turn white, the best way to handle this problem is to wait until the humidity situation improves and apply another coat of dope. This will eliminate the blush. If it is necessary to dope during high humidity, Sig Retarder may be used in place of part of the Supercoat Thinner (amount depends on the humidity) to reduce the tendency to blush.

Painting the entire model white is recommended for a good color base, particularly when white is part of the color scheme. Color coats can be sanded with 360 Tri-M-lite or 400 or finer wet paper. When using masking tape for trimming, seal the edge with a coat of clear dope to prevent the color dope from bleeding under the edge. Don't leave the masking tape on any longer than necessary. The longer it is on, the harder it sticks.

Patterns are shown on the plan for the curved decoration which are not on the decal sheets. Masking off these curved parts for painting is made much easier if 1/8" wide masking tape is used. This will bend around corners easier than wider tape. Strips can be cut off regular width tape with a straightedge. After the decoration is outlined, wider tape can be joined onto the 1/8" tape to block off the nearby areas not to be painted. We use paper taped on to match the rest of the model to shield for spray painting.

Another way the curved parts of the decorations can be applied is with the use of a mechanical drawing ruling pen to draw them on the model using paint in the pen instead of ink. Thin the dope slightly with blush retarder to slow the drying process and aid the flow of dope through the pen points. Clean the pen frequently with dope thinner and wipe on a cloth before reloading with fresh dope. Don't try to draw a thick line with the dope and pen but instead draw a thin line on each side of the desired pin stripe (about 1/8" wide were used on the original) and fill in between the lines using the pen free hand and opened up for a wider flow. If you have a steady hand, use a small brush. Use a French curve to outline curved parts of the decorations.

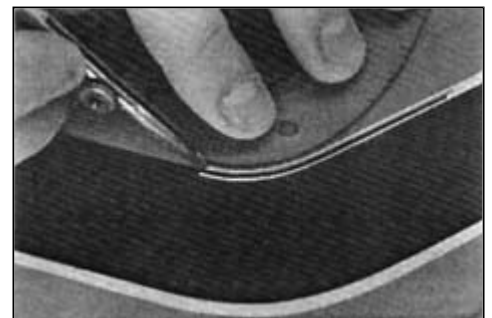

The ruling pen method is also handy to touch up any rough edges of a masked decoration after the tape is removed.

Complete the job with several sprayed coats of clear over the color scheme. This seals the colors and adds gloss. For best results, it is not a good idea to try and mix different brands of paint. Use Sig products from the start.

## Painting The Canopy

We recommend Sig Plastinamel for painting the framing outlines on the canopy. Dope is very difficult to use on a canopy plastic because of its warping action. Epoxy paint can be used, but it does not stick on the plastic quite as well as Plastinamel. Sanding the gloss off the plastic will help adhesion. Other enamels and plastic paints probably can be used, but test in advance, because no assurance can be given for other types.

### T-38 Style Kobra Bottom Color Scheme

The wing stripes are blue and the center spar is red. The front stripe is 3" wide with a 1/2" white gap between it and the 2" wide rear stripe.

### F-16 Style Kobra Bottom Color Scheme

The fuselage bottom spar is red. The nose color of the F-16 is black back to the rear of the canopy on top.

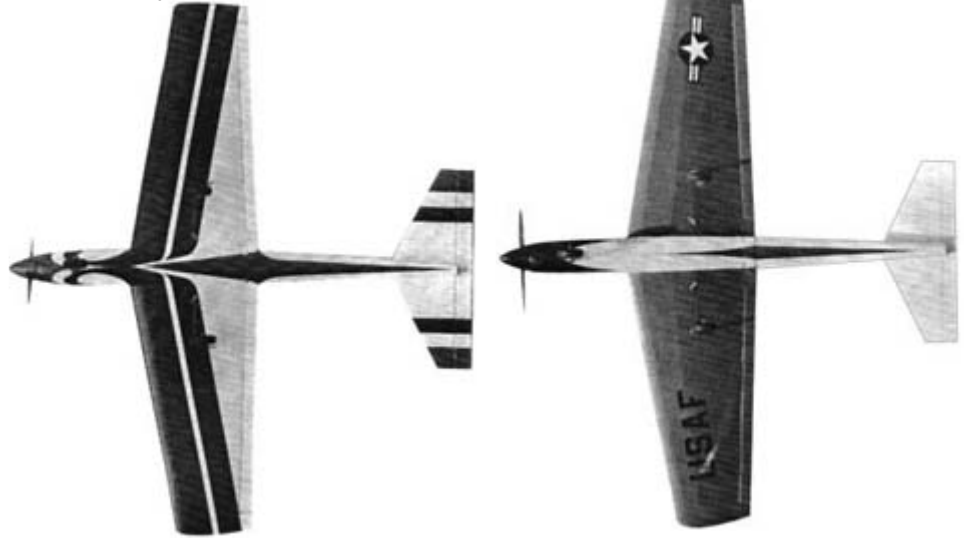

## Decals

### Stik-Tite Pressure Sensitive

Cut out the decals with a pair of sharp scissors. Leave about 1/32" to 1/16" of clear edge around the decal. Round the corners as you are cutting.

Wet the surface on which the decal will be placed with soapy water (use dishwasher detergent). Place the decal on the model and squeegee the water from underneath with a balsa paddle. Allow to dry. This procedure will prevent air from being trapped underneath as is possible when the decals are applied dry.

### A CURE FOR FUSELAGE WARPING

You may have noticed when a piece of balsa is doped on one side and not the other, it will curl. The same thing can happen on the fuselage sides, under the wing opening, particularly when you put on a number of coats. (The rest of the fuselage will not show this effect to any extent because it is four sided and cannot distort.) The effect isn't noticeable until after full cure of the dope and aging, which may take several months. To prevent this from happening, give the inside fuselage a coat of dope every time you give the outside a coat. This has an added advantage in making the cabin area fuel proof. In addition, when the hardwood servo mounts are installed, have them a little over-long so that the cabin sides are bulged slightly outward.

## Balancing

### BALANCE POINT RANGE:

Test fly with the balance point located at 3-3/8" back from the front fuselage-wing joint. If your model will spin in both directions at this balance point it need not be moved any farther back unless experimentation with balance trim during aerobatic flying shows the need to do so. The Kobra flies best balanced farther forward than is common practice with this type of model. Do not assume that it should be balanced at some other percentage point because of your experience or that of expert fliers in your club with a farther back balance point. Like the Kougat (which is sometimes flown at a more conventional balance point by modeler's who do not believe our instructions - and subsequently have bad results including snap rolls at low speed), the Kobra is notably stable and forgiving during low air speed situations yet is fully aerobatic in the balance range indicated.

### WHY MODELS MUST BE INDIVIDUALLY BALANCED

It is impossible to produce a kit that will automatically have the correct Center of Gravity (C.G.) position. Balsa wood varies in weight and it is easily possible for wood in the tail to be an ounce or more heavier or lighter than average. One ounce of extra weight in the tail has to be countered by about 3 ounces in the nose. Don't pile a lot of fillercoat or finish, use excess glue or make large fillets on the tail surfaces. The motor you choose, whether or not a muffler is fitted, the size and placement of your radio equipment, etc. all affect the balance. If you use an unusually heavy motor or muffler you may have to carry the battery in the radio compartment instead of the nose or even weight the tail. Don't consider that whatever C.G. the model builds out to as "good enough". Check carefully and make whatever adjustments that are required. With the C.G. properly located, a Sig design should fly with only minor trim changes required.

## .....Kobra flies best balanced farther forward than is common practice with this type of model.....

Flying with the balance point any farther back than 3-5/8" from the front wing fuselage joint is not recommended unless you are an expert flier with a purpose for doing so.

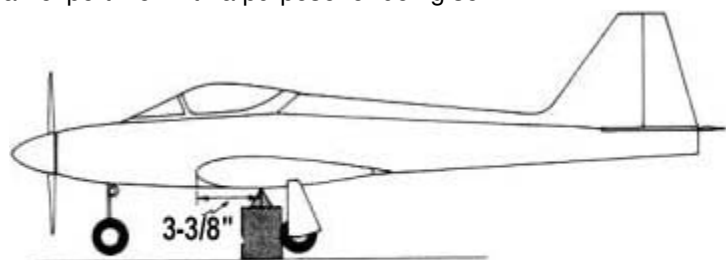

**Kobra prop size recommendations:**

9-4 for .19, 9-5 for .25, 9-6 for .30 and 9-6 or 10-6 for .35

Put a piece of masking tape on the bottom of the wing in the center. Mark the distances from the leading edge (the wing fuselage joint) on it. A balancer can be made from a triangular architect's scale placed on a block high enough to get the wheels clear of the bench. Shift the model back and forth on the edge of the scale until the balance point is found. Balance with an empty fuel tank but with all the other equipment installed and the model completely finished and painted.

If the tail hangs down at the desired balance point, it is tail heavy. Add lead or weight to the nose or shift the radio equipment as necessary to get it to sit level. Do not attempt flight in a tail heavy condition.

In addition to the fore and aft balancing procedure described above, the performance of maneuvers is improved if the model is also in balance spanwise. For example, if one wing is heavy it may affect turning and loop tracking. Inset weight into the opposite wing tip to correct this problem.

## Control Movements

Various brands of servo can give different control movement direction and amounts of travel. For this reason, follow the measurements when setting the Kobra up for flight. Shift the RC link to whatever horn hole will produce the amount of movement shown in the drawings. Measurements are made at the trailing edge of the control surface.

The control measurements are suggested as a beginning. Test flights may indicate a need for more or less movement, depending on individual model differences, center of gravity (C.G.) location, your personal preference, etc.

Should the servo output arm or wheel provided on the radio equipment not provide enough movement of the surfaces, accessory output arms that are longer are available for most radios, either from the manufacturer or other sources such as Rocket City.

It is not uncommon for the best elevator neutral position to test out to be slightly off from level. This introduces some nose up or down trim to keep the model from climbing or diving when the transmitter stick is in the center. The exact best neutral elevator position for each particular model must be determined during flight testing. With the model flying at about 3/4 throttle, feed in up or down trim in with the transmitter lever until the model flies level. Land and observe this position of the elevator. Adjust the elevator pushrod as required to keep the flight checked "neutral" position when the transmitter trim lever is returned to the center. Don't have excessive elevator control movement. If you are not using full stick movement to make the tightest desired maneuvers, reduce the movement until full transmitter stick travel is used.

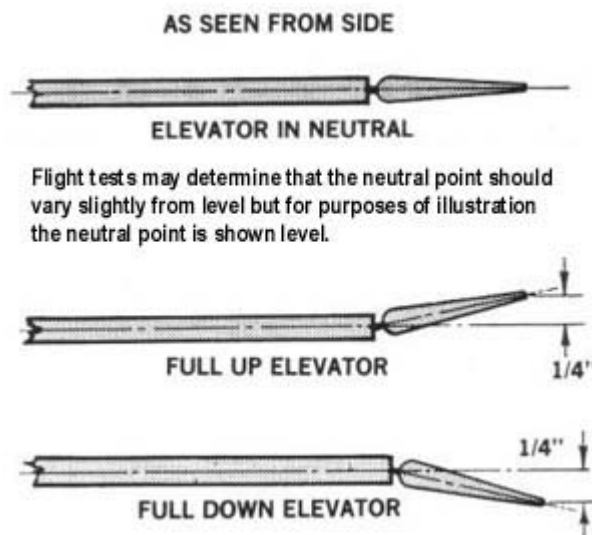

The adjustable nylon fittings on the aileron horns supplied with the Kobra provide a fairly good range of possible movement adjustment. Screw the nylon fitting in toward the wing to get increased movement of the ailerons and out away from the wing to get decreased movement. Check your neutral position (or whatever amount of trim displacement you have from neutral) before altering the amount of up and down movement because these points will likely be changed by the raising or lowering of the nylon fitting and will need to be re-established by lengthening or shortening the adjustable RC clevises on the aileron servo pushrods that snaps onto the fitting as required to return the neutral points to where they were originally.

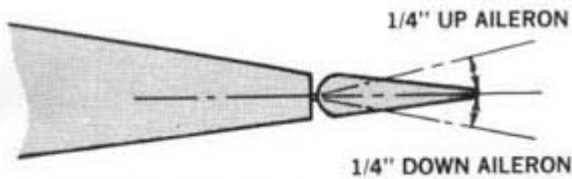

Special Note: Neutral for the aileron is not in line with WP, but is positioned in line with the wing.

Set neutral at this approximate point for test flying.

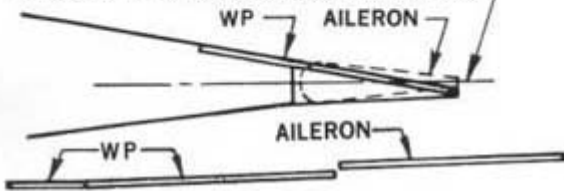

Rear View Approximate relationship of trailing edges.

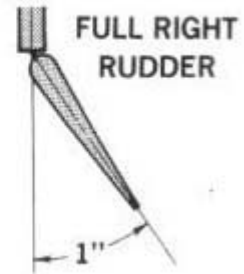
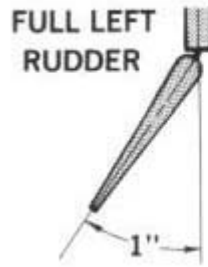

### BALANCE IS PART OF THE TRIMMING PROCESS

The balance point we arrived at for this design is a good place to start when trimming out the model for top performance. However, it should not be considered the final and irrevocable location. Individual models built from the same kit are slightly different from each other. The incidence may be changed a bit, a small or large engine selected, the total weight varies - even the skill of the pilot has a bearing on just what should be the exact C.G. point. For example, when slightly nose heavy, the model is more stable and less likely to stall or snap roll from over-elevating. This also cuts down the reaction of the model to control movements which is good during test and practice flights to help prevent over controlling. But later, if extra sensitivity and quick reactions are desired for aerobatic performance, a position farther back may be desirable. So try different positions, but make the changes gradually, checking results and the effect of the change control responses and the performance of the model in the air at a good altitude.

### Scale Details

The cowl, as described in the instructions and plan, was left open in the top for easy access. However, if you like a slicker appearance, and don't mind the tighter access to the interior, the cowl can be built up a bit more by gluing pieces of scrap sheet around the top before carving. The accompanying photo of one of the prototype models shows the effect this additional fill-in provides.

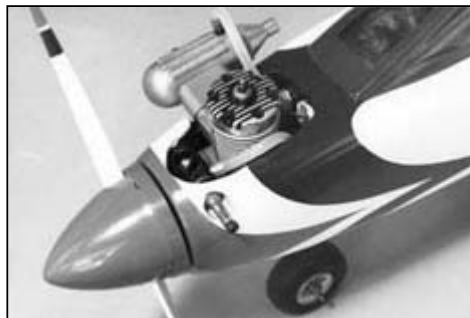

Above are the decal sheets for the Kobra. All color decorations not on the decal sheets were painted on the prototypes with Sig Supercat dope. See the finishing section for details on how this was done.

In addition to the method described there, using 1/8" wide masking tape on the curves, it is possible to make good use of the common adhesive-backed vinyl shelf paper available at hardware stores. Using a new blade in a modeling knife, cut the color sweep on the T-34 version for example out of a piece of the shelf paper and use the mask remaining for spraying or hand painting the decoration on the tail. For models covered with plastic film, the fin flash could be cut from sheets. Or follow the manufacturer's directions that come with the plastic film for applying this type of decoration. On the original prototypes, a small wing fillet of Sig Epoxolite was installed. The main purpose of this was to make a good seal at the wing fuselage joint. It was put on after the model was silked and doped up to the point of color doping.

Here is the procedure for making an Epoxolite fillet:

- a. Mask off the side of the fuselage where the Epoxolite will be applied. On a model the size of the Kobra it need not be a very wide strip - about 1/8" was used on the prototypes.
- b. Tape a strip of wax paper on top of the wing on each side where the fuselage will touch the wing.
- c. Apply a bead of Sig Epoxolite to the fuselage side bottoms.
- d. Put the wing on and bolt in place. This will cause the putty to squeeze out from under the fuselage onto the wax paper protective strips on the wing.
- e. Spread the excess putty onto the 1/8" strip of exposed fuselage side and start a rudimentary fillet shape.
- f. After the Epoxolite has gotten partly stiffened, shape the fillet further using a wetted finger or tool of the desired shape.
- g. Allow the Epoxolite to set up.
- h. As soon as it is hard, but not fully cured, remove the wing.
- i. Trim off the excess that squeezed into the inside of the fuselage.
- j. Even the outside edge of the fillet and shape the fillet with a round tool covered with coarse sandpaper - 60 or 80 garnet. If you use fine paper it will clog up to rapidly. Be careful not to sand through the masking tape protecting the fuselage, but sand down to it so that the tape can be peeled off, leaving a clean edge on the fillet.
- k. After the fillet has cured (24 hours), fine sand it and feather the edge formed by the masking tape into the fuselage side.

Don't get carried away with this idea, it can get heavy. Keep the fillet small. A model the size of the Kobra is a better flier if the wing loading is kept in a reasonable range.

## FLYING

---

**IMPORTANT:** The Kobra is not a basic trainer, if you have no previous RC flying experience you cannot successfully fly a fast and responsive design like the Kobra, particularly on test flights. Do not attempt flying the model without the assistance of an experienced RC flier. Contact your local model club or ask your hobby dealer for the names of good fliers in your vicinity and a suitable location for RC flying.

Be certain to carefully range check your radio equipment and see how it operates with the engine running before attempting test flights. A lot of problems can be avoided if the engine has been well broken-in and the idle adjustment perfected on a test block or in another airplane before installation in this model.

Takeoffs with the Kobra from grass fields are easily made if the grass is not too long or the ground too rough. Generally a lot of elevator application is required for liftoff. Be prepared to relax control pressure particularly after becoming airborne so the climbout will not be too steep. On surfaced or smooth dirt runways less application of elevator will be needed.



Use the ailerons or rudder to keep the wings level and headed straight into the wind until about 75 feet of altitude is obtained. Keep first turns gentle and not steeply banked. Stay up wind of the transmitter. Use trim levers on your radio equipment where necessary to obtain straight and level flight with the control sticks in neutral position but don't attempt to make these adjustments until the model is at a good altitude. Throttle back at the altitude to find out the model characteristics in a gliding condition so that some indication is seen of what to expect during the landing approach. It is a good idea to make several practice landing approaches at a good altitude to get the feel of the model for this approaching critical maneuver. Make your final and complete landing approach while your engine still has plenty of fuel remaining so that the engine is not liable to stop before completion of the flight. This will allow application of power if the approach is being under shot. Notice the percentage of missed landings at an R/C field. Those undershot greatly outnumber those missed by overshooting. So if an approach that looks a little high is maintained, chances are good that a spot-on landing can be made.

After you get through the first flights you should begin to "trim" the model's control surfaces. If it is turning to the right, for example, with the stick in neutral, and you must move the transmitter trim lever to the left to make the model fly straight, then land the model and position the rudder to the left of center by turning the RC link on the pushrod one or two turns on its threads. Check in the air for the result. Repeat the process, if necessary, until the trim lever is centered when the model is flying straight with the stick in neutral.

You may find that the reaction of the model is different to high and low power, requiring changes in trim lever position during flight, as for a landing approach. This is one of the controls you must learn to operate during practice flying, but it is not a critical matter at first since these minor corrections can be made with stick movement alone as you are steering the model along its course.

It is impossible to give exact directions for every case, since individually built models vary slightly and the engine used also affects results. But if the model is not flying in a satisfactory manner, the chances are it is not trimmed properly and should be adjusted accordingly. Do a little tinkering, a bit at a time. This is an instructive way to fathom the mysteries of perfect trim and in the process you can improve your flying performance considerably.

## **Grass Field Flying**

If your flying field is not smooth, paved or closely cropped grass, lift off qualities on takeoff will be improved by bending the main landing gear forward so that the wheel position is up to 1" farther ahead than that shown on the plan. This makes it easier to rotate into lift off attitude as up elevator is applied during the takeoff run through the grass. The model will not stick on the ground quite as well using this forward landing gear position when landing on paved surfaces, but not to any troublesome degree.

---

© Copyright SIG Mfg. Co., Inc.

**SIG MFG. CO., INC.....Montezuma, Iowa 50171-0520**

### **LIMIT OF LIABILITY:**

In use of our products, Sig Mfg. Co.'s only obligation shall be to replace such quantity of the product proven to be defective. User shall determine the suitability of the product for his or her intended use and shall assume all risk and liability in connection therewith.