



## INTRODUCTION

The MID-STAR 40 was designed for mid level R/C pilots who are looking for an easy-to-build sport plane. Its mid wing and light weight combine to make it a stable platform for novices moving up from their high wing trainer. Advanced pilots will find the MID-STAR 40 is capable of almost any trick "in the book", yet will slow down for soft gentle landings. It can be flown from pavement or grass, and it handles the wind well for such a light model.

Easy construction was a top priority for this design. The Lite-Ply fuselage virtually snaps together and results in a strong, lightweight structure. The wing has no leading edge sheeting, which helps speed construction. The simple, pre-cut balsa tail parts also save time. The model can be completely covered with iron-on film, with only a small amount of painting required.

One important decision that you will need to make before building is whether to use tricycle landing gear on your MID-STAR 40 or make it a taildragger. New pilots who are transitioning from a tri-gear trainer may want to stick with the tricycle setup, which generally helps to make takeoffs easier. The main advantage of choosing the optional taildragger version is that you will save considerable weight (no nose gear), resulting in increased performance. The tail dragger version handles very well on the ground - if you've always wanted to try a taildragger, this would definitely be a good one to start with.



## Recommended Glues

There are so many different glues available today for model construction that it can be confusing to even the experienced modeler. To simplify matters, most glues can be classified as one of four basic types:

1. Fast-drying cyanoacrylate adhesives ( abbreviated in these instructions as "CA") such as SIG CA, Hot Stuff, Jet, etc .....
2. Easy-to-use water-base wood glues such as SIG-BOND (yellow) and SIG SUPER-WELD (white).
3. Super strong two-part epoxy glues such as SIG KWIK-SET (5-minute cure) and SIG EPOXY (3-hour cure).
4. Traditional solvent-base model cements such as SIG-MENT.

Each of these types has different characteristics and advantages. Often times, the choice of which type to use is strictly a matter of personal preference based on your prior experience with a previous model. However, because of the vast use of Lite-Ply and hardwoods in the MID-STAR 40, we have found that the CA glues seem to work the best for general construction. In fact, the construction sequence of the fuselage is designed with the use of CA glue in mind. Other glues could be used, but CA is recommended as our first choice because of its ability to penetrate an already assembled joint. In other words, the fuse parts can first be assembled dry (without glue), the alignment checked and adjusted, and then the glue can be applied to the joints. You should also have on hand some epoxy (both 5-minute and slow dry) and Sig-Bond because these glues are called out in several of the steps in this book.

Sig CA, like most brands of cyanoacrylates, comes in three viscosities - thin, medium and thick. An accelerator spray and debonder are also available and are described below.

- **Sig CA Thin** - Watery in consistency, thin CA should only be used when the two parts to be joined are in perfect contact with zero gap. Capillary action pulls this glue deep into the wood resulting in a very strong bond and it dries in just a few seconds. Thin CA can be used to tack assemblies together, but these joints should be glued again later with medium or thick CA. Thin CA is also necessary for installing EASY HINGES.
- **Sig CA Medium** - Our medium thickness CA is excellent for almost any step during construction, and is particularly recommended for gluing the plywood fuselage parts. The extra thickness allows the glue to fill small gaps, but it dries a little slower than thin CA. If you want only one type of CA, use medium thickness.
- **Sig CA Slow** - This thickest formula is good for filling large gaps and building up strong fillets at joints requiring extra strength. It also dries slow enough to allow you to apply it to one part and position it on another before it dries. (With thin and medium CA's, the parts must be in contact and positioned correctly before glue application.) This feature is useful when laminating large sheeted areas like a fuselage side and a fuselage doubler.
- **Sig Kwik-Shot Accelerator** - Spraying accelerator on CA (any thickness) will cure it almost instantly. Although CA is fast, it's sometimes nice to speed it up even more.
- **Debonder** - This can be used to separate parts, but you'll probably use it for unsticking your fingers more than anything else!

### CAUTION:

Some people have experienced allergic reactions when exposed to epoxy or cyanoacrylate glues. This is very rare. However, it is always important that such glues, and also paints, thinners, and solvents, be used with adequate ventilation to carry fumes away.

## Engines, Propellers, And Mufflers

There is a tremendous variety of engines available in the size range specified for the MID-STAR 40. Both 2-stroke and 4-stroke engines work equally well in this model, so choose your favourite type, keeping in mind the type or performance that you wish the model to have.

<b>Recommended Engine Range:</b>	<b>.30 - .40 2-Stroke</b>
	<b>.40 - .50 4-Stroke</b>

If you want maximum aerobatic capability and vertical performance, use an engine towards the upper end of the recommended size range. If the MID-STAR 40 is your first move up from a trainer, engine sizes from the bottom of the range may suit you better. Engines at the bottom of the range will still put the MID-STAR 40 through most aerobatic maneuvers.

Use only propellers recommended in the instructions supplied with your engine. If you use a very high-power engine in your model (such as a schneurle-ported 2-stroke .40), it's recommended that you opt for a propeller with a relatively large diameter and low-pitch. This will give you loads of pulling power during maneuvers without a lot of excess speed. If you build the tricycle-gear version and fly off grass, the prop diameter should be kept at 11" or less. If you fly off a hard-surface, you can use up to a 12" dia. prop.

There is no one type of muffler that is best suited to the MID-STAR 40. It all depends on the particular engine that you have selected. If you have a 2-stroke engine, use the muffler that was supplied with it or one of the many aftermarket mufflers that are available. As with any mid-wing model, it's a good idea to install a commercially-available exhaust diverter to keep the engine exhaust from hitting directly on the leading edge of the wing. Most 4-stroke engines don't require a muffler because of their low noise production. Angle the exhaust stack on your 4-stroke engine up and away from the model.

## Radio Requirements

A four-channel radio system is required for the MID-STAR 40 to operate the ailerons, elevator, rudder, and throttle. The fuselage is spacious enough that any common brand of radio equipment with standard size servos and battery pack can be used. Be certain that your radio system's frequency is approved for use in R/C model aircraft.

## You Can't Get Along Without A Good Sanding Block

An assortment of different size sanding blocks are indispensable tools for model construction. A good general purpose block can be made by wrapping a 9"x11" sheet of sandpaper around a piece of hardwood or plywood. Use three screws along one edge to hold the overlapped ends of the sandpaper. Put 80-grit paper on the block during general construction. Switch to 220 grit paper for final sanding just before covering.

In addition to the large block, there are places where a smaller one is handy. Also, a sandpaper "file" can be made by gluing sandpaper to a flat spruce stick for working in tight places.

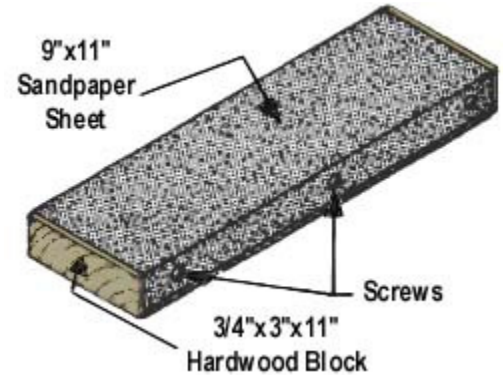

## About The Building Sequence

The quickest and most efficient way to complete a model is to work on several pieces at the same time. While the glue is drying on one section, you can start on or proceed with another part. Work can even go forward on several sections of the same assembly at the same time, such as the front and rear sections of the fuselage.

Keep in mind that the number sequence used in these instructions was chosen as the best way to explain the building of each major component and is not intended to be followed in exact one-two-three fashion. Start on the wing at No.1 and after doing as many steps as is convenient, flip over to "FUSELAGE CONSTRUCTION" and do a step or two there, then back to "WING CONSTRUCTION" and so forth. You will, of course, arrive at points where you can go no farther until another component is available. Plan ahead, read the instructions completely and study the full size plans before beginning construction.

## Refer To "The Basics Of Radio Control"

"The Basics of Radio Control" booklet has been included with this kit as a reference for installing the engine, fuel tank, and radio in the MID-STAR 40. It also contains very important information on preparing the model for flight. Modellers of all experience levels are encouraged to read this book and follow its guidelines for success.

### COMPLETE KIT PARTS LIST

COMPLETE KIT PARTS LIST							
<b>Die-Cut Balsa Sheets</b>							
3	3/32"x3"x9" W-1 Wing Ribs	4	3/32"x3"x 18" W-2 Wing Ribs				
<b>Sheet Balsa</b>							
2	1/16"x1-1/4"x30" Top Trailing Edge Sheeting	2	1/16"x1-1/2"x30" Bottom Trailing Edge Sheeting	2	1/16"x3"x30" Wing Center Sheeting, Top and Bottom	18	3/32"x3"x1-3/16" Shear Webs (3 bundles of 6)
1	1/4"x4"x6" Hatch						
<b>Stick Balsa</b>							
6	3/16"x3/16"x30" Front Spars, Rear Spars	2	1/4"x1/4"x30" Trailing Edges	2	5/16"x5/16"x30" Leading Edges	1	1/4"x1"x3-5/8" Nose Brace
2	1/4"x1"x4-3/16" Stab Tips	1	1/2"x30" triangle Braces for F-1, Wing Hold Down Blocks, Landing Gear Bolck and Fin (optional)				
<b>Special Shaped Balsa</b>							
1	3/16"x2-1/2"x9" Pre-Cut Rudder	1	3/16"x4"x8-1/2" Pre-Cut Fin	2	1/4"x2'x9-1/2" Pre-Cut Elevators	1	1/4"x5"x18" Pre-Cut Stabilizer
2	1/4"x1"x30" Ailerons (tapered, with rounded edge)	2	1/4"x1/4"x18" Fuselage Stringers (beveled edges)				

<b>Die-Cut Poplar Plywood (Lite-Ply)</b>					
2	1/8"x5-1/4"x43-1/2" Fuselage Sides	2	1/8"x5-1/4"x24" Fuselage Doubler, Servo Rail Supports, Wing Tip Brace	1 1/8"x4-1/2"x43-1/2" FBR, FTR, BP, CF-1, CF-2, Stab Support, Stab Tip Template	1 1/8"x6"x32" F-2 thru F-6, F-2D, F-3S, F-4S, Wing Tips, Hatch Plates, Dual Tool, RCG-1, RCG-2
1	1/8"x18"x4-1/2" FBF, Tank Floor				

<b>Die-Cut Birch Plywood</b>					
1	3/32"x6"x9" F-1, Dihedral Brace, Hatch Tongue				

<b>Sawn Birch Plywood</b>					
2	1/16"x3/4"x1-1/2" Wing Hold-Down Plates	1	1/4"x1-1/2"x3-1/4" Landing Gear Mount		

<b>Hardwood</b>					
4	3/16"x3/8"x30" Spruce Main Wing Spars	1	1/4" dia.x2-1/2" Birch Wing Hold-Down Dowel, Canopy Hold-Down	2 1/4"x1/4"x2" Basswood Grooved Torque Rod Blocks	2 1/4"x7/8"x2" Basswood Wing Hold-Down Blocks
1	3/8"x3/8"x12" Basswood Servo Rails, Canopy Hold-Down Block				

<b>Formed Wire Parts</b>					
1	1/16" dia.x4-1/2" Tailwheel Wire	1	3/32" dia.x4" Elevator Joiner	1 5/32" dia.x12-1/2" Nose Gear Strut	1 4-40 x5" Threaded Rod, L.H. Aileron Torque Rod (with 1/8"o.d.x1-1/2" Brass Bearing)
1	4-40 x5" Threaded Rod, R.H. Aileron Torque Rod (with 1/8"o.d.x1-1/2" Brass Bearing)				

<b>Formed Plastic Parts</b>					
1	.040 Clear Plastic Canopy	1	.030 ABS Plastic Canopy Base		

<b>Miscellaneous</b>					
2	Glass Filled Engine Mounts	1	.090 Aluminum Landing Gear	1 1"x24" Fiberglass Tape (for wing center and tailwheel wire)	2 6-3/4"x27" 3-Color Decal
1	Full Size Printed Plan	1	Photo Illustrated Instruction Booklet	1 "The Basics Of Radio Control" Booklet	

<b>Hardware</b>					
4	#2 x1/2" Sheet Metal Screws (for control horns)	2	4-40 x3/8" Flat Head Mounting Bolts (for hatch)	1 4-40 x 3/8" Mounting Bolt (for canopy hold-down)	8 4-40 x1/2" Mounting Bolts (for nose gear bearing and landing gear)
4	6-32 x3/4" Mounting Bolts (for engine mounts)	2	8-32 x1-3/8" Mounting Bolts (for wheel axles)	2 1/4-20 x1" Nylon Wing Bolts	1 #4 Flat Washer (for canopy hold-down)
10	4-40 Blind Nuts (for nose gear bearing, landing gear, and hatch)	4	6-32 Blind Nuts (for engine mounts)	4 8-32 Hex Nuts (for wheel axles)	1 4-40 Brass Threaded Insert (for canopy hold-down)
2	Solder Link (for throttle and nose wheel)	1	2-56 Threaded Coupler (for throttle pushrod)	5 2-56 Nylon R/C Links (2/aileron, 1/rudder, 1/elevator, 1/throttle)	6 2-56 x 10" Threaded Rods (2/aileron, 1/rudder, 2/elevator)
1	Set of 2 Nylon Aileron Connectors	1	5/32" Nylon Nose Gear Bearing	1 5/32" Nylon Steering Arm (w/brass insert and set screw)	2 Nylon Control Horns (1/rudder, 1/elevator)
1	Pushrod Connector Assembly (for steering arm)	2	.190 o.d. x24" Nylon Outer Tubing (for rudder and elevator pushrods)	2 .130" o.d. x30" Nylon Inner Tubing (for rudder and elevator pushrods)	2 .130" o.d. x15" Nylon Inner Tubing (for throttle and nose wheel pushrods)
2	1/16" dia. x15" Steel Cable (for throttle and nose wheel pushrods)	15	3/4"x1" Easy Hinges		

3/32"x3"x18" Balsa - 4 req.

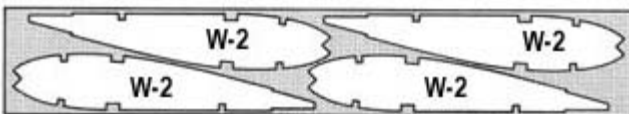

3/32"x3"x9" Balsa - 3 req.

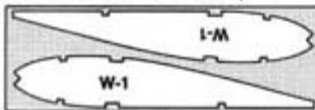

1/8"x6"x32" Lite-Ply - 1 req.

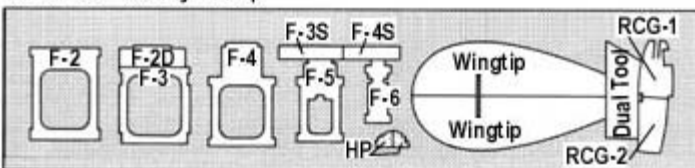

**KEY TO DIE-CUT PARTS**

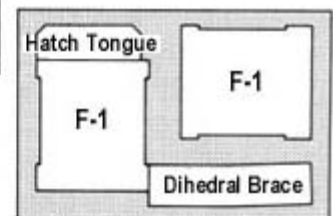

3/32"x6"x9" Birch Ply - 1 req.

## Notes Before Beginning Construction

Any references to right or left refers to your right or left as if you were seated in the cockpit.

To build good flying models, you need a good straight building board. Crooked models don't fly well! The building board can be a table, a workbench, a reject "door core" from the lumber yard, or whatever - as long as it is perfectly flat and untwisted. Cover the top surface of the building board with a piece of celotex-type wall board or foam board, into which pins can be easily pushed. Don't hesitate to use plenty of pins during assembly to hold drying parts in correct position.

When pinning and gluing parts directly over the full-size plans, cover the plan with wax paper or plastic kitchen wrap to prevent gluing the parts to the plans.

Don't use a ball point pen for making marks on the model during construction. If not sanded off, these ink marks will show through the model's final finish. Use a pencil instead of a pen.

Leave all die-cut parts in the sheets until needed in construction. Then remove the pieces from the sheets carefully. If difficulty is encountered, do not force the part from the sheet - use a modeling knife to cut it free.

The die-cut balsa and plywood parts can be identified using the plans and the "Key To Die-Cut Parts" above. Mark the identification numbers on the corresponding parts before removing them from the die-cut sheets.

All of the other parts can be identified by the "Complete Kit Parts List" above. Sort the different sizes of sticks and sheets into individual piles to avoid confusion during building.

## WING CONSTRUCTION

Before beginning wing construction, carefully splice together the Left Wing Panel plans so that the "X" and "Y" indicators meet. Use a straightedge to double check the alignment of the plans before taping them at the seam. Tape or pin the plans to your building board and protect them with a layer of waxed paper. Build each wing half separately.

1.
  - a. Pin the 3/16"x3/8"x30" spruce main wing spar in place on the plan. Be careful not to place pins where they will interfere with wing ribs which will be added later.
  - b. Pin the 1/16"x1-1/2"x30" balsa bottom trailing edge sheeting in place.
  - c. Use about three wing ribs to accurately position the 3/16" sq. x30" balsa rear spar, then pin the spar in place.
2.
  - a. Glue eight W-2 wing ribs to the spars and trailing edge sheeting.
  - b. Place scraps of 1/16" balsa near the main spar to accurately space the W-1 wing ribs up from the building board. (The spacing is required for the center sheeting to be added later.)
  - c. Use the dihedral guage side of the die-cut Dual Tool to set the root W-1 rib at the proper dihedral angle before gluing it in place. Add the two remaining W-1 ribs.
3.
  - a. Glue the 1/4" sq. x 30" balsa trailing edge to the top of the T.E. sheeting and the ends of the wing ribs.
  - b. Remove the pins in the bottom T.E. sheeting and re-pin the back of the wing through the trailing edge stick that you just installed.
  - c. Add the 1/16"x1-1/4"x30" top trailing edge sheeting. For this step it is recommended that you use Sig-Bond (alphatic resin) along the back edge of the sheeting that glues to the trailing edge. That will make the joint easier to sand when you reach step 11. Use thin CA to tack the front edge of the sheeting to the wing ribs.

1/8"x18"x4-1/2" Lite-Ply - 1 req.

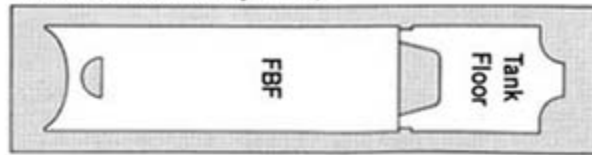

3/32"x3"x18" Balsa - 4 req.

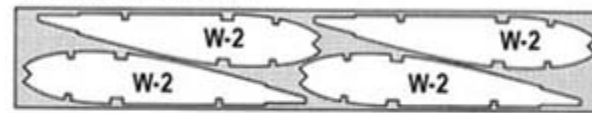

1/8"x5-14"x24" Lite-Ply - 2 req.

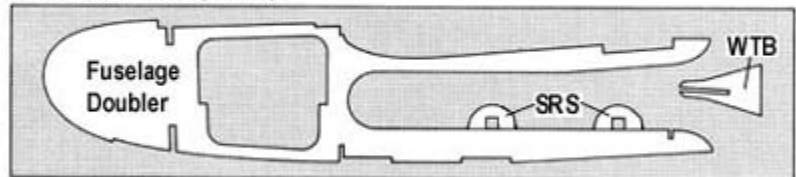

1/8"x5-1/4"x43-1/2" Lite-Ply - 2 req.

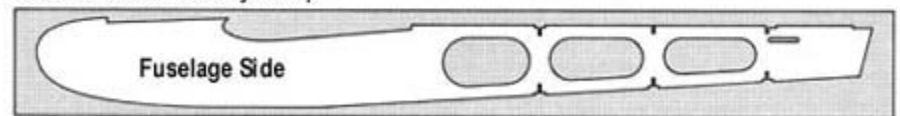

1/8"x4-12"x43-1/2" Lite-Ply - 1 req.

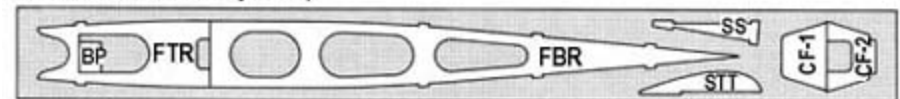

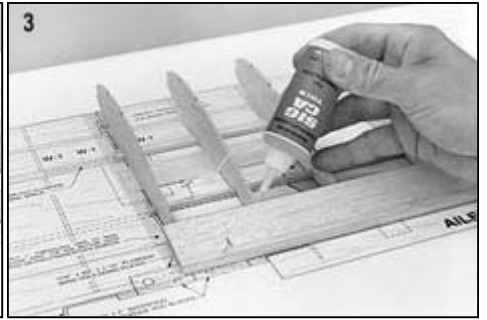
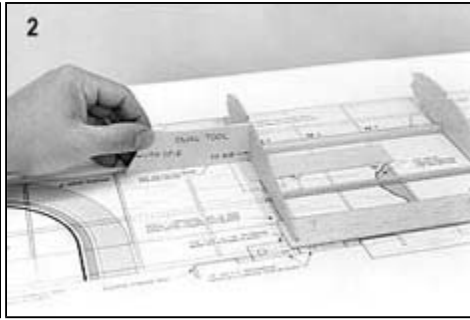
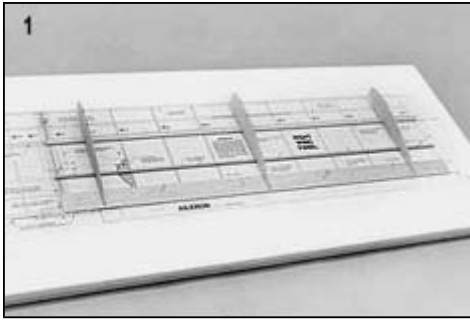

4. Install a pre-cut  $3/32 \times 3 \times 1-3/16$ " balsa shear web in each rib bay except the one between the two most inboard W-1 ribs (where the dihedral brace will be installed later.) Notice that the wood grain is vertical for maximum strength. Trial fit each web before gluing, sanding the ends as necessary to make them fit snugly between the ribs at either side. The bottom of the shear webs should be centered on the bottom main wing spar; the top of the shear webs should be centered on the notch for the top main wing spar.

NOTE: The shear web to be installed between the second and third W-1 wing ribs will need to be shortened significantly to fit.

5.
  - a. Trial fit the  $3/16 \times 3/8 \times 30$ " spruce top main wing spar. If any of the shear webs are too tall, they should be trimmed to allow the spar to sit all the way down in the rib notches. When satisfied with the fit, glue the spar in place. Check the inboard W-1 rib again with the Dual Tool to be sure it is still at the correct angle.
  - b. Glue the  $5/16$ " sq.  $\times 30$ " balsa leading edge to the front of the ribs.
  - c. Glue the  $3/16$ " sq.  $\times 30$ " balsa top forward spar in the rib notches.

NOTE: Remove any pins from the structure that are located under the area where the top center sheeting will be installed (in the next step). Otherwise, you may find it difficult to remove your wing from the board later!

6. Pieces for the top center sheeting should be cut from the  $1/16 \times 3 \times 30$ " balsa provided in the kit. Again, Sig Bond is recommended for the front and rear edges of the sheeting to make it easier to sand the joints smooth. Also use Sig-Bond on the center W-1 rib. The sheeting can be glued to the ribs on each end using CA.

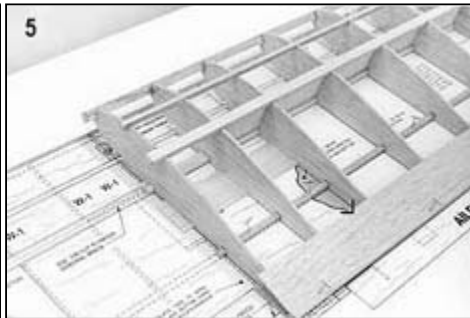
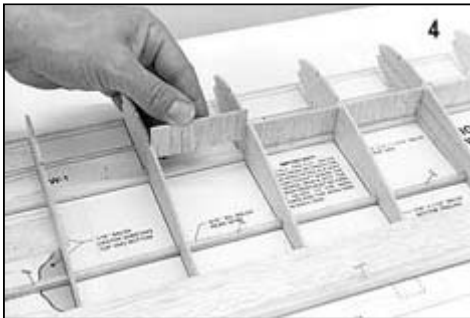

7. When the glue has dried, unpin the wing half from the board and install the  $3/16$ " sq.  $\times 30$ " balsa bottom forward spar. **IMPORTANT:** If you have been using thin or medium CA glue during construction, now is the time to go back over every joint using medium or thick CA. Don't be stingy here - the integrity of your wing depends upon strong glue joints. Glue each side of each joint. Make certain the shear webs are bonded to the spars AND the wing ribs on each side. Double check the L.E. stick and the T.E. sheeting for complete bonding to the ribs.
8. Install the bottom center sheeting except in the area between the bottom forward spar and the bottom main wing spar. Cut pieces for the sheeting from the  $1/16 \times 3$ " balsa that you used earlier.
9. Cut off and sand the spars. L.E., T.E., and sheeting at both ends of the wing flush with the end ribs.
10. Sand the leading edge to a round cross-section as shown in the diagram below.

NOTE: The L.E. notches in the ribs were intentionally made slightly oversize so the ribs could be sanded down to the leading edge.

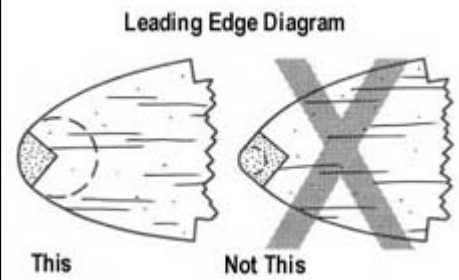
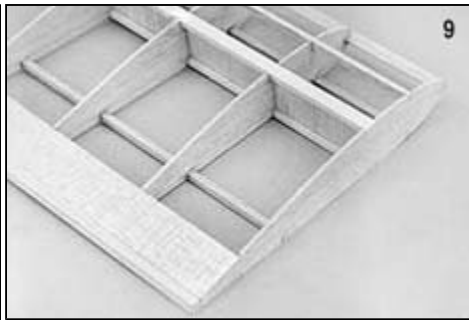
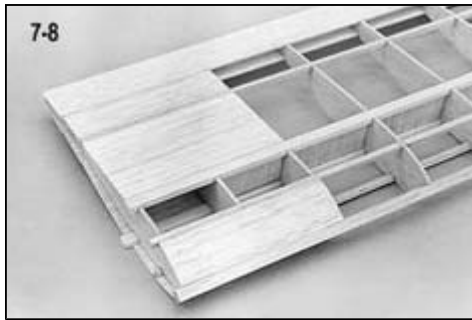

11. Carefully carve the top of the trailing edge to match the slope of the to T.E. sheeting using an X-Acto #26 whittling blade. Wrap the top of the blade with masking tape (to protect sheeting), leaving about 1/2" exposed at the base. Use the masked portion to guide the blade at the correct angle. Final sand the T.E. so that the back edge of the wing is about 1/4" thick (same as the ailerons).
12.
  - a. Glue the die-cut Lite-Ply wingtip brace (WTB) onto the die-cut Lite-Ply wingtip. When dry, sand off the rounded ends of the wingtip brace as shown in the diagram.
  - b. Glue the wingtip assembly to the outer end of the wing panel. Notice that the wingtip cants slightly upwards (when viewed from the rear).
  - c. Add scraps of balsa to the top and bottom of the rear edge of the wingtip. Carefully sand the balsa to blend into the wing trailing edge.

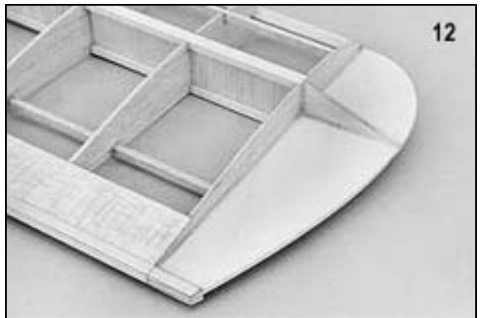
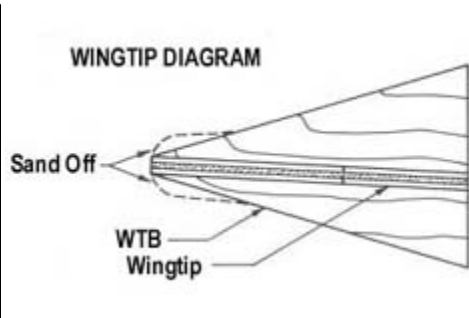
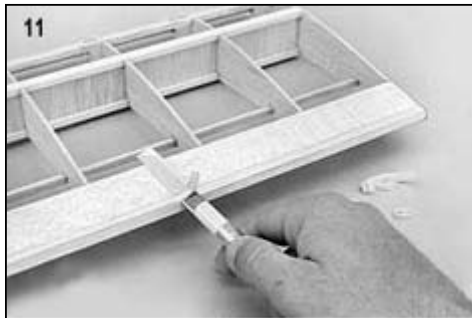

13.
  - a. Sand the top center sheeting smooth. (The bottom center sheeting is sanded in step 22.)
  - b. Position the die-cut Lite-Ply rib cutout guide #1 (RCG-1) on the inboard W-1 wing rib. The top of RCG-1 should be flush with the top of the center sheeting, and the notches at the rear should fit around the main wing spars. Trace the notches for the wing hold-down dowel and the canopy hold-down block with a sharp pencil.
  - c. Remove the guide, then measure and mark the cutout area on the top center sheeting using the dimension shown in the photo. Using a modeling knife, carefully cut out the outline area. Also cut the slot for the wing-hold down dowel, but do not cut into the leading edge.
  - d. Position the die-cut Lite-Ply rib cutout guide #2 (RCG-2) on the inboard W-1 wing rib. The bottom edge of RCG-2 should be flush with the bottom surface of the wing sheeting. Trace around RCG-2.
  - e. Remove the guide, then measure and mark the cutout area on the bottom center sheeting as shown in the photo. Cut out the outlined area with a modeling knife. This step accomplishes two things. First it clears an area for the aileron servo; and second, it provides an open area between the main wing spars for the dihedral brace.

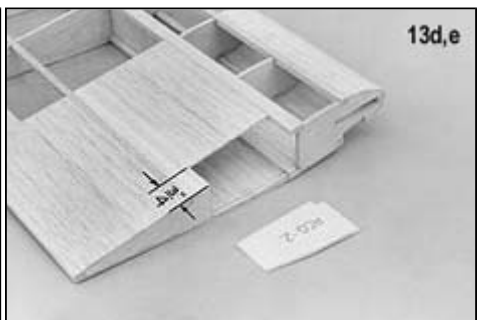
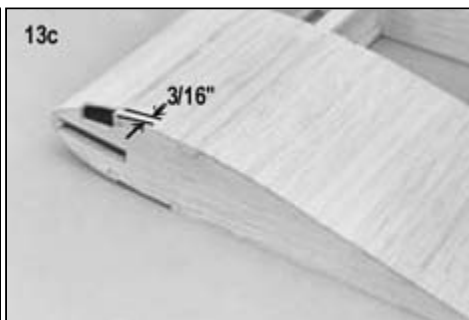

14. Set this wing panel aside, and repeat steps 1 through 13 to build the opposite wing half.

## Joining The Wing Panels

15.
  - a. Trial fit the two wing halves with the dihedral brace installed between the main wing spars. Be certain that the dihedral brace is not preventing the panels from making solid contact with each other at the center. If necessary, trim or sand the dihedral brace for a snug fit.
  - b. Glue the dihedral brace into ONE of the wing panels. Make certain that it is positioned accurately between the main wing spars.
  - c. Use slow CA or epoxy (either 5-minute or slow-dry) to join the two wing panels. Apply glue to the end ribs and the exposed edges of the dihedral brace, then carefully slide the other wing panel into place. Before the glue dries, make certain that the leading and trailing edges of each panel are aligned. The dihedral angle of 1 deg. per wing panel will be automatically built in by the dihedral brace. If you want to check the angle, place the wing on a table so that one wing panel sits flat, and the other is raised. The distance from the table to the bottom of the outmost wing rib should be 1"; although a variation of up to 1/4" either way is acceptable. The most important thing is to have a solid joint at the wing center with no gaps.
  
16.
  - a. When dry double check through the servo opening and center sheeting opening on the bottom that the dihedral brace is glued solidly to the main wing spars and the W-1 wing ribs.
  - b. Glue the die-cut Lie-Ply backplate (BP) into the aft end of the servo opening. When dry, trim BP flush with the bottom center sheeting.
  
17.
  - a. The aileron torque rods have been pre-bent so that the threaded portion leans rearward slightly inside the fuselage (see the W-1 wing rib cross-section on the plans). That small angle will provide your MID-STAR 40 with a bit of differential movement (more up than down) in the ailerons, which makes for smoother rolling characteristics. Prepare the torque rods for installation by roughening the brass bearings with sandpaper, then wiping them clean.
  - b. Locate the 1/4" sq. x2" basswood grooved torque rod blocks and cut a notch in each of them as shown in the photo.
  - c. Glue the torque rods into the blocks being very careful not to get any glue in the brass bearings. The outer end of the bearings should be even with the outer end of the blocks.

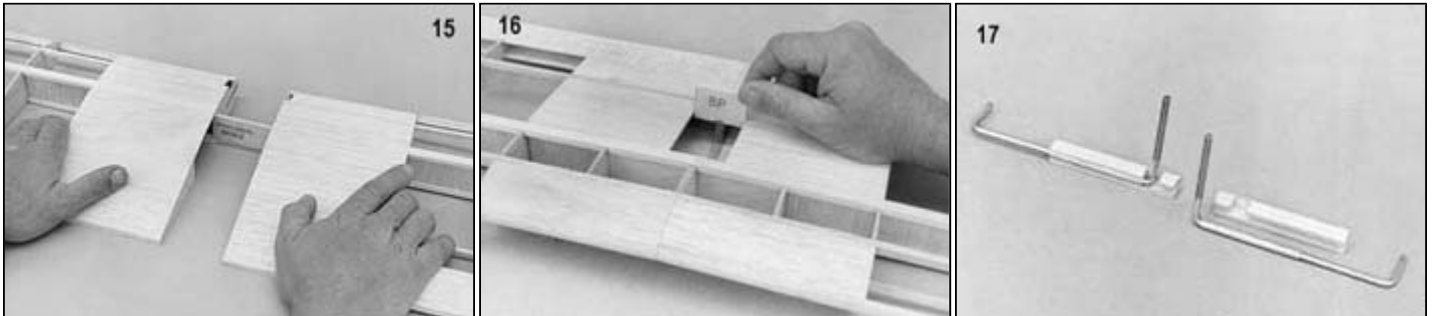

18.
  - a. Glue the torque rod/block assemblies in place on the wing T.E., again being very careful not to get any glue in the bearings.
  - b. Notch the balsa trailing edge just forward of the notches in the torque rod blocks to allow full movement of the torque rods.
  - c. Sand the top of the basswood blocks to match the slope of the trailing edge sheeting. A small sanding block is handy for this step.

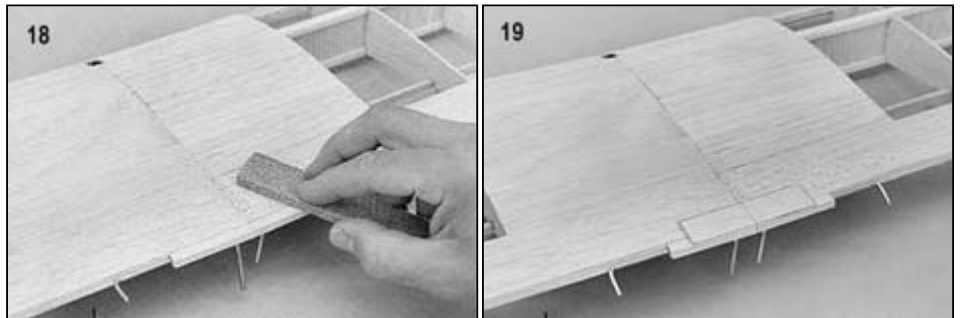

19. Glue the 1/16"x3/4"x1-1/2" plywood wing hold-down plates to the top of the wing, even with the back of the torque rod blocks.

NOTE: Complete the steps in "Mounting The Wing To The Fuselage" before proceeding.

## Finishing The Wing

20. The canopy hold-down block is a 3/4" long piece of basswood cut from the 3/8" sq. x12" stick supplied in the kit. Glue the block firmly in place, then sand it as necessary to make it flush with the top of the wing.



21. Finish off the bottom center sheeting, again using 1/16" balsa.
22. Give the wing a final sanding with a long sanding block. Sand just enough to take off any prominent high spots or bumps. Excessive sanding may distort the airfoil shape. Any dents or gouges in the wood can be filled with a lightweight wood filler.
23. The 1" wide fiberglass tape can be applied to the wing center joint (top and bottom) using one of the following methods.

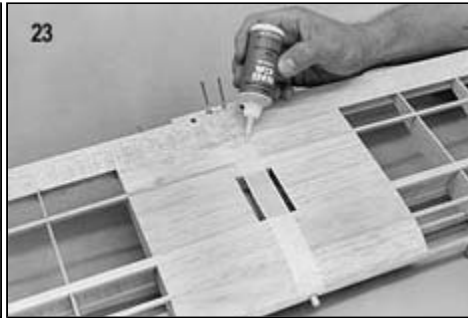
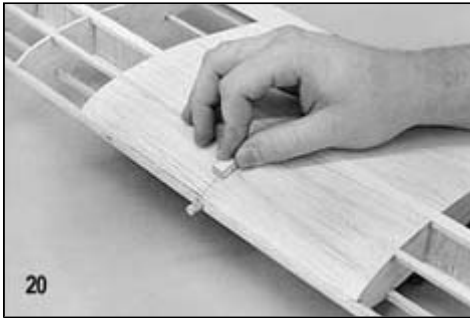

Remove the tape from the servo cutout area after the glue is dry.

#### METHOD 1:

- a. Coat the wing center joint with slow-drying epoxy glue.
- b. Lay the tape on the top of the glue
- c. Holding one end of the tape so it won't slip, "squeegee" the glue through the tape with a small paddle of scrap balsa. Scrape over the tape several times with the paddle to smooth the tape and remove any excess glue.
- d. When dry, sand lightly to remove any rough spots. Try not to sand into the fiberglass tape itself.

#### METHOD 2:

- a. Cut the tape to length, then lightly spray one side with a spray adhesive (such as 3M "77").
- b. Position the tape on the wing center joint.
- c. Soak the tape with CA. The spray adhesive simply holds the tape in place - it won't affect the strength of the CA. A second coat of CA will help to fill in the weave of the fiberglass, resulting in a smoother surface. Rub the second coat with your finger (protected with plastic wrap - keep it moving!) to smooth out the glue. Use a fan to keep the CA fumes away from your face.
- d. When dry, sand lightly to remove any rough spots. Try not to sand into the fiberglass tape itself.

## Ailerons

24. The leading edge of each aileron is pre-shaped, but they need to be sanded lightly to a smooth, round contour. Position the ailerons on the back of the wing, leaving a 1/32" gap between the inboard ends of the ailerons and the outboard ends of the torque rod blocks. Mark the locations for the torque rods, then slot and drill the aileron leading edges to receive the torque rod wires.
25. Trial fit the ailerons to the torque rods. Once they fit, temporarily tape the ailerons in place and sand their outboard ends to match the curve of the wingtips. The outer edge of the ailerons and the scrap balsa on the T.E. of the wingtips should be rounded off so that they blend together perfectly.

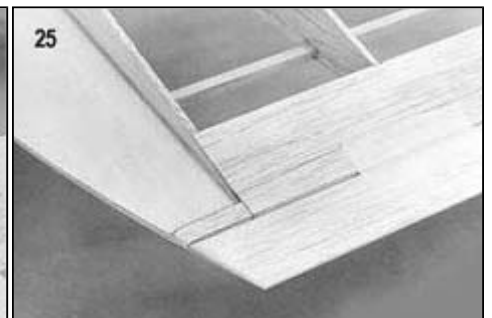

## FUSELAGE

Before starting fuselage construction, there are a few subassemblies that should be built and set aside until needed. This is done to avoid interruption during the flow of the fuselage construction.

26.
  - a. Glue together the two die-cut plywood F-1 pieces using Kwik-Set epoxy or slow CA. Use a heavy weight of some kind to hold down the two pieces perfectly flat while drying.
  - b. Mark the vertical centerline and thrust line on the F1 assembly using the cross-section on the plan as a guide.
  - c. Determine the spacing that will be necessary between the two glass filled engine mounts to fit your engine. Position the mounts on F-1 accordingly. Mark the location of the four mounting holes and drill them out with a 3/16" drill bit.
27. Lightly hammer four 6-32 blind nuts into the back of F-1. Bolt the engine mounts to the front of F-1 using 6-32x3/4" mounting bolts to align the blind nuts (see note below). Apply medium or slow CA around the edges of the blind nuts to hold them in place. Be careful not to get any glue in the threads.

NOTE: The shank of the 6-32 blind nuts may extend too far through F-1 and interfere with the back of the engine mounts. To avoid any conflict, drill a 1/4" dia. relief partially through the back of the mounts at each hole.

28. Position your engine on the mounts far enough forward for the propeller to clear the fuselage "cheeks" and mark the engine mounting holes. Remove the mounts, then drill at the marks with a bit that's just large enough to clear your engine mounting holes.
29. Re-intall the engine mounts, then bolt the engine in place. Use 3/4" long bolts (4-40 or 6-32, depending on the engine) and matching aircraft lock nuts to fasten the engine to the mounts (engine mounting bolts and nuts are not included in the kit). Locate and mark the best spot on the firewall for the throttle pushrod to exit and line up with your engine's carburetor control arm. Drill at the mark with a 9/64" drill bit. Remove the engine and engine mounts.

NOTE: If you are building the optional taildragger version of the MID-STAR 40, skip steps 30 & 31 and proceed with step 32.

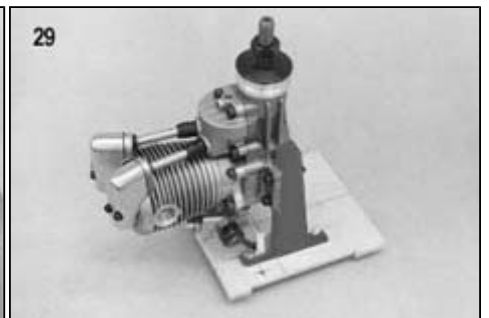
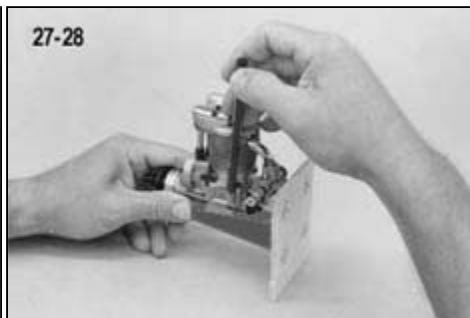
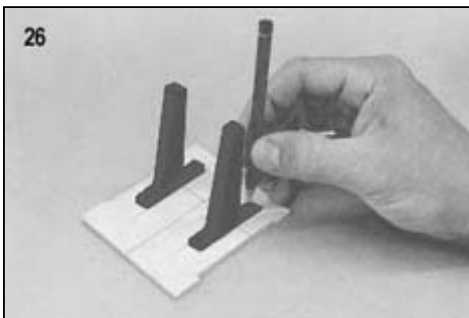

30.
  - a. Carefully center the molded nylon nose gear bearing over the center line on F-1. Be certain that the bottom edge of the bearing is flush with the bottom edge of F-1. Mark the location of the four mounting holes through the holes in the bearing.
  - b. Remove the bearing and drill at the marks with a 5/32" drill bit.
  - c. Lightly hammer four 4-40 blind nuts into the back of F-1 at the four holes, and secure them with medium or slow CA.
31.
  - a. Bolt the nose gear bearing to F-1 with 4 4-40 x 1/2" mounting bolts.
  - b. The Sig Pushrod Connector included in the kit is used to connect the flexible cable nosewheel pushrod to the molded nylon steering arm. Snap the pushrod connector onto the outer hole of the steering arm, then assemble the steering arm and formed nose gear strut into the nose gear bearing (as shown in the "Nose Gear Assembly" drawing on the plan).
  - c. Turn the steering arm back against F-1 and mark the location of the nosewheel pushrod through the hole in the pushrod connector. Remove the nose gear assembly, then drill at the mark with a 9/64" drill bit.

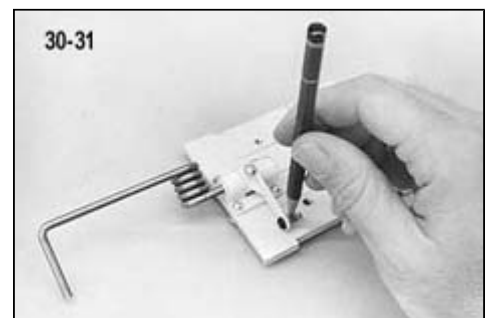

32.
  - a. Carefully center the aluminum landing gear over the 1/4"x1-1/2"x3-1/4" plywood landing gear mount and mark the location of the four mounting holes through the holes in the landing gear and drill at the marks with a 5/32" drill bit.
  - b. Lightly hammer four 4-40 blind nuts into the holes and secure them with medium or slow CA.

33.
  - a. The die-cut Lite-Ply former F-2D has a dimple in the center to mark the correct position of the hole for the wing hold-down dowel. Glue F-2D to the front of die-cut Lite-Ply former F-2 so that the dimple remains showing.
  - b. Carefully drill at the dimple with a 1/4" drill bit. Use a chunk of hardwood behind the former to keep the wood from splintering as you drill through.
34. Glue the die-cut fuselage doublers to the die-cut fuselage sides using slow CA or Kwik-Set epoxy, and allow to dry. Be sure to make one left side and one right side!

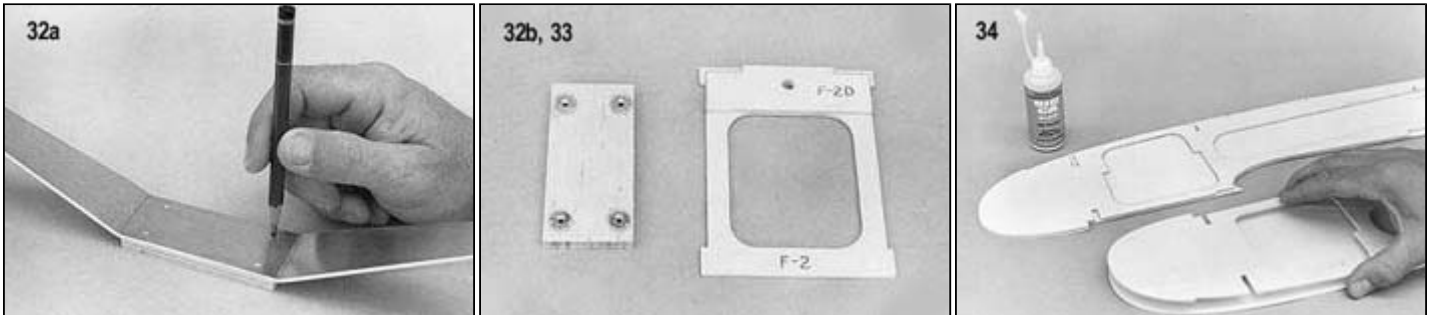

## Basic Fuselage Construction

35.
  - a. Tape or rubber band the fuselage sides together at the rear.
  - b. Working from the rear forward, slip all the fuselage formers (F-6 thru F-1) into place. Put a rubber band around the fuselage at each former location to hold it tightly together.
  - c. Slide the die-cut Lite-Ply part FBR (fuselage bottom, rear) under the rubber bands until it snaps into its proper location between the fuselage sides.
  - d. Slide the die-cut Lite-Ply part FTR (fuselage top, rear) into place under the rubber bands.

NOTE: The "Tee-Lock" tabs on the formers, FBR, and FTR are made oversized to protrude past the fuselage sides. These will be sanded off after the fuselage has been completely assembled.

36.
  - a. Place the fuselage over the top view on the plans to check its alignment. Correct if necessary by twisting gently before proceeding. View the fuselage directly from the rear to be certain that the joint where the fuselage sides meet is square with the fuselage bottom.
  - b. Carefully glue all of the parts permanently in place, preferably working from inside of the fuselage, using medium CA. Start with small patches of glue in the corners, checking the fuselage alignment as you go. Then go back and glue all of the joints on both sides. Leave the rubber bands and tape in place until all of the glue has dried completely.
37. Glue the die-cut Lite-Ply cockpit former #2 (CF-2) on top of FTR using the 30 deg. side of the Dual Tool to get the correct angle. Don't bevel the bottom edge of CF-2, and make certain that it is flush with the front edge of FTR.

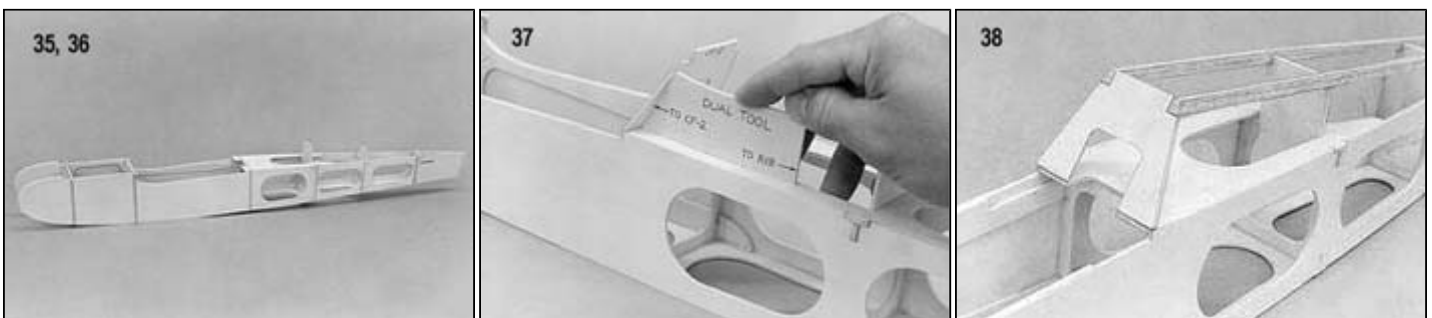

38.
  - a. Glue the two 1/4" sq. x 18" special shaped balsa stringers into the notches on the formers.
  - b. When dry, trim off the ends of the stringers flush with the front face of CF-2 and the rear face of F-6.

NOTE: If you are building the optional taildragger version of the MID-STAR-40, skip step 39 and proceed with step 40. If you are building the standard tricycle gear version, perform step 39, skip step 40, and proceed to step 41.

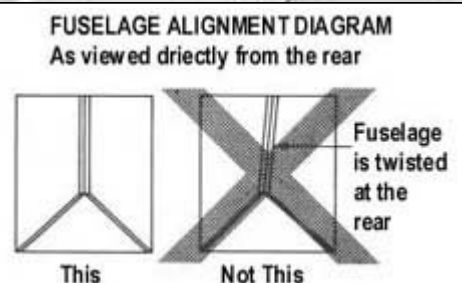

39.
  - a. Install the landing gear mount in the rear notches of the fuselage doubler by gluing it firmly to the sides, the doublers, and FBR.
  - b. Tape the die-cut Lite-Ply piece FBF (fuselage bottom, front) in place, recheck the fuselage alignment over the plans, then glue it using medium CA. Be sure to firmly glue the joints between FBF and the landing gear mount, F-1 and F-2 from the inside of the fuselage.
  - c. If necessary, use a modeling knife to trim the back edge of the hole in FBF so that it's flush with the front face of F-1.

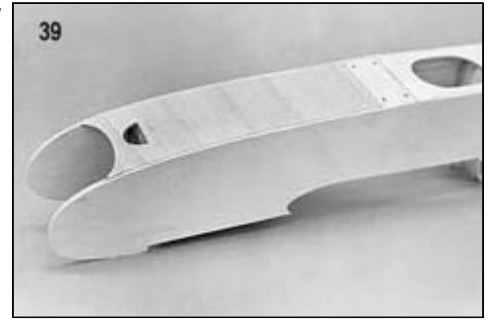

40.
  - a. Install the landing gear mount in the front notches of the fuselage doubler by gluing it firmly to the sides, the doubler, and F-2.
  - b. Cut the die-cut Lite-Ply piece FBF (fuselage bottom, front) into two pieces as shown in the diagram.
  - c. Tape the two pieces of FBF into place on the bottom of the fuselage, recheck the fuselage alignment over the plan, then glue it all using medium CA. Be sure to firmly glue the joints between FBF and the landing gear mount, F-1, and FBR from the inside of the fuselage.

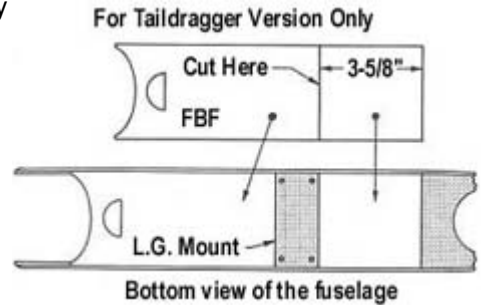

41.
  - a. Cut two 1-1/2" lengths from the 1/2"x30" balsa triangle stock to serve as braces for the landing gear mount. Notch both braces to clear the blind nuts, then glue them in place.
  - b. Cut two braces for F-1 from the 1/2" balsa triangle stock and notch them as necessary to clear the blind nuts on the back of F-1. Apply slow CA to the braces and press them firmly in place.
  - c. Install the die-cut Lite-Ply tank floor so that it is sealed on the fuselage doublers and against the back of F-1, then glue it in place.

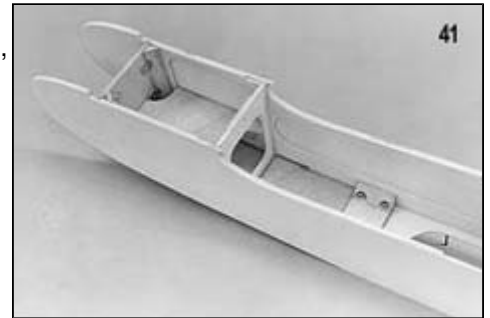

42.
  - a. Glue the 1/4"x1"x3-5/6" balsa nose brace to the top of the fuselage and F-1.
  - b. When dry, hold the die-cut 3/32" plywood hatch tongue in position and draw a line on the tongue at the back of the nose brace.



43.
  - a. Remove the hatch tongue, center it on one end of the 1/4"x4"x6" balsa hatch, and glue it so that the line on the tongue is flush with the end of the hatch.
  - b. Glue the two die-cut Lite-Ply hatch plates (HP) into place.

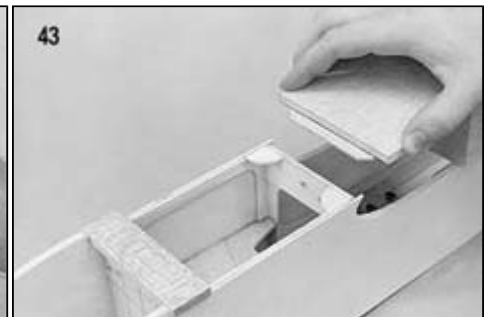

44.
  - a. The hatch is cut oversize so that it can be sanded to match the fuselage. Spot glue the hatch in place using two spots of slow CA on the top edge of fuselage sides.
  - b. The fuselage is now ready for final sanding. Sand off at the "Tee-Lock" tabs then round the bottom edges of the fuselage, the fuselage nose, and the sides of the nose brace and hatch. Use a sanding block, starting with 80-grit sandpaper. Switch to 150-grit sandpaper for the final sanding.
  - c. The balsa stringers already have an angled side, but for the smoothest finish you need to sand the angle slightly. Wrap one end of your sanding block with paper, then slide the wrapped end against the top edge of the fuselage as you sand. Once you've sanded the angle, round off the top outside corner of each stringer with your sanding block.



45. With the hatch still spot glued to the fuselage, use the plan as a guide to carefully mark the location of the two hold-down screws. Drill completely through the hatch and hatch plates at the marks with a 1/8" drill bit.
46.
  - a. The aft end of the hatch needs to be beveled at about a 45 deg. angle to allow the wing to slide into place. Mark the hatch on each side and along the top where it is to be cut off.
  - b. Remove the hatch by carefully cutting at the glue spots with a single-edged razor blade or modeling knife. Saw off the excess material at the aft end, then sand in the bevel using your marks as a guide.
  - c. The holes for the flat-head hold-down screws can be countersunk using a sharp 1/4" drill bit. Strengthen the countersunk area with a few drops of thin CA.
  - d. Redrill the two hatch plates with a 5/32" drill bit, then install two 4-40 blind nuts in the holes from the bottom. Secure the blind nuts with medium or slow CA.

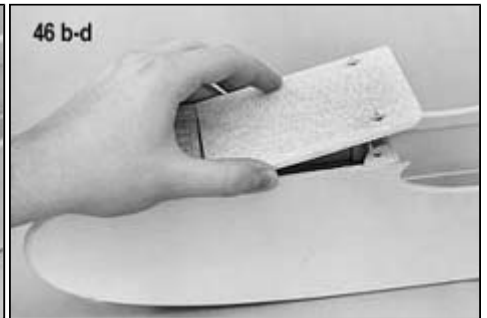
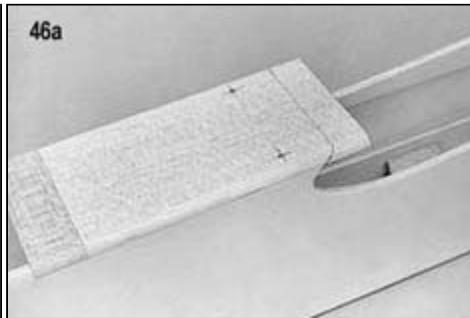
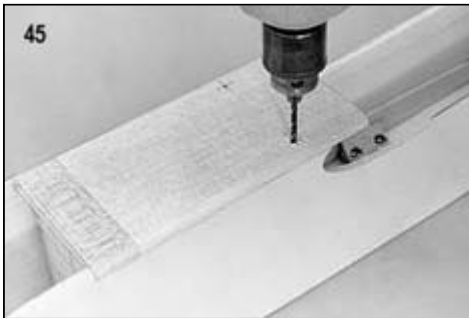

## Mounting The Wing To The Fuselage

NOTE: The wing must be finished through step 10 before proceeding.

47.
  - a. Locate the 1/4" dia. x2-1/2" dowel and cut off a 2" long piece to serve as a wing hold-down dowel. Save the remaining piece for the canopy hold-down dowel.
  - b. Sharpen one end of the wing hold-down dowel to a point - keep the point symmetrical and centered. With the hatch removed, push the dowel into the hole in F-2 so that only the point sticks out into the wing opening. Slide the wing into position, making sure it is centered on the fuselage. When you remove the wing, there should be a small indentation in the leading edge. (If not try using a drop of paint on the pointed dowel, which will transfer to the wing L.E.)
48.
  - a. Drill a 1/4" dia. hole through the L.E. at the indentation.
  - b. Remove the dowel from F-2, then reinsert it from the wing opening about 5/16".
  - c. Trial fit the wing in position, sliding it onto the dowel. Check to see that the wing seats properly on the fuselage. If not, slowly enlarge the hole in the L.E. until it does seat properly. If necessary, sand the back edge of the basswood torque rod blocks to allow the wing to seat firmly on the fuselage.
  - d. With the wing still in position, apply medium CA or epoxy to the wing dowel and W-1 wing ribs by working through the openings in the wing. Be careful not to allow the glue to run down and bond the dowel to F-2.
  - e. When dry, remove the wing and fill any gaps around the dowel with another application of glue.



49.
  - a. The 1/4"x7/8"x2" basswood wing hold-down blocks key into notches in the fuselage doubler. To accurately fit them, temporarily tape or pin the wing in place on the fuselage.
  - b. Working through the lightening holes in the fuselage, install the wing hold-down blocks in the notches, making certain they are in full contact with the wing bottom surface. Tack glue the blocks to the fuselage to hold them in position, then remove the wing. Finish gluing the blocks in place using medium CA.
  - c. Cut two 2" lengths of 1/2" triangle stock to brace the wing hold-down blocks. Glue the triangle braces firmly to the hold-down blocks and the fuselage doublers.



50.
  - a. Fit the wing in place on the fuselage and check its alignment (see the General Alignment Drawing on page 20 of "The Basics of Radio Control" booklet). When you are satisfied that it is aligned correctly, tape it so that it can't move.
  - b. Carefully mark and drill locations for the wing hold-down blocks at the same time with a #7 (or 13/64") drill bit. Keep the drill perpendicular to the top surface of the wing so the heads of the nylon bolts will seat flush against the plywood plates.

51.
  - a. Remove the wing and tap the wing hold-down blocks with a 1/4-20 tap. You can apply a few drops of thin CA to the holes to strengthen the threads.
  - b. Redrill the holes in the wing with a 1/4" drill bit to pass the nylon wing bolts.

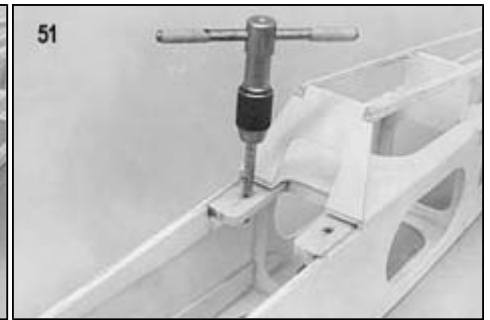
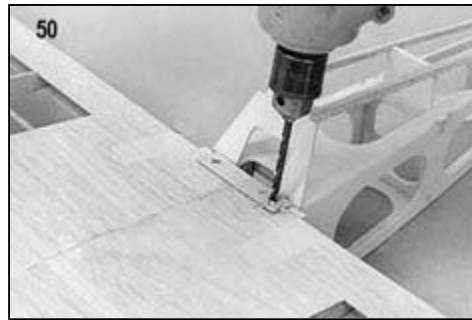

52.
  - a. The servos need to be mounted in the fuselage so that the nylon pushrods can be routed properly, with the least amount of curvature. Refer to Chapter 2 of "The Basics Of Radio Control" and the plans for information on where and how to mount the servos in the fuselage. Start by cutting two 3-1/4" long servo rails from the supplied 3/8" sq. basswood. Use the servo tray provided with your radio to properly space the rails along the "flat" edges of the fuselage doublers. When satisfied with their position, glue the servo rails in place.
  - b. Lock the rails in place by gluing a die-cut Lite-Ply servo rail support (SRS) at each end of both rails.



53.
  - a. Locate the two .190 o.d. x24" nylon outer pushrod tubes, and roughen the last 3" of each with sandpaper to aid glue adhesion.
  - b. Slide the outer pushrod tubes forward through the pushrod exit slots in the fuselage sides and the notches in F-6. Continue sliding the tubes until only about an inch of the roughened end sticks out of the slots.
  - c. The outer pushrod tubes should meet (but not cross) at the notch in F-5. Glue a scrap of balsa below the tubes to hold them in place.
  - d. Apply glue liberally (either slow CA or epoxy) to the outer tubes at the pushrod exit slots, from both the inside and the outside of the fuselage.



54.
  - a. Use a single-edge razor blade to trim the outer pushrod tubing flush with the outside of the fuselage.
  - b. Install the die-cut Lite-Ply stab support (SS) so that it is flush with the top of the fuselage sides.
  - c. When dry, sand the "Tee-Lock" tabs on the stab support flush with the fuselage sides.

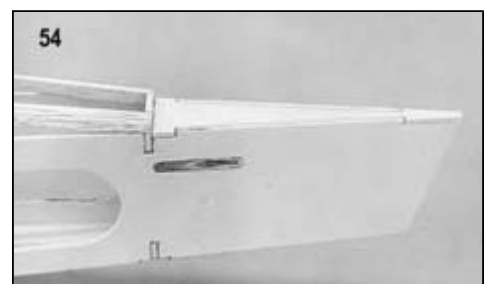

- 55.
- The nylon pushrods must be supported at each former to keep them from flexing under load. Use the die-cut Lite-Ply pushrod straps, F-3S and F-4S, to support the pushrods. Notice that the pushrod straps haven't been marked for pushrod location because the routing of the pushrods will vary with different servo installations. Ideally, you want to have the pushrods to come through F-3S pointed directly at the servo arms of the rudder and elevator servos. Carefully mark drill locations on the pushrod straps for the two nylon pushrods. Drill at the marks with a 3/16" drill bit.
  - Slide F-4S then F-3S into position on the pushrods, but don't glue them yet.
  - Cut off the front ends of the outer pushrod tubes about 2" short of the servo arms.

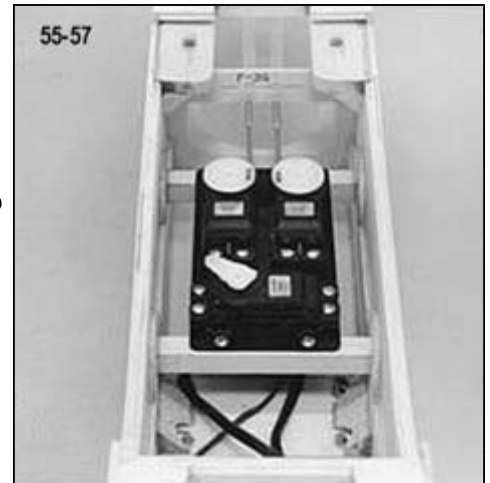

- 56.
- Cut two 2-56 x10" threaded rods to an overall length of 2-1/2", measuring from the threaded end. Put a "Z" bend in the non threaded end of the rods. Of course, another type of servo connector may be used if you prefer (see page 7 of "The Basics Of Radio Control").
  - Screw the threaded end of the rods completely into the two 130" o.d. x 30" nylon inner pushrod tubes.
  - Slide the inner pushrod tubes into the outer tubes from the servo end. Install the "Z" bends (or your alternate servo connectors) on the servo arms and hook them into the servos.
57. With the pushrods hooked up to the servos you can now glue F-3S and F-4S to the front of F-3 and F-4, respectively, in such a way to keep the bends at a minimum.
58. This is a good time to plan your fuel tank installation and routing of fuel lines through F-1 (see "Engine And Fuel Tank Installation" in the "Final Assembly" section of these instructions). Assemble your fuel tank (following the manufacturer's instructions and position it in the fuel tank compartment. Mark the locations of the fuel lines on F-1, remove the fuel tank, then drill holes through F-1 at the marks using a drill bit that's the same diameter as the fuel tubing you plan to use. You should also redrill the holes for the throttle and nosewheel pushrods (9/64" dia.), since they were both probably covered up by the triangle braces installed in step 41.

## Canopy Installation

59. NOTE: The wing must be finished through step 25 before proceeding.
- Trim the plastic canopy base to the molded-in trim lines. With the wing firmly bolted to the fuselage, tape the canopy base in position on top of the wing. Confirm that the front of the "console" is centered on the wing.
  - Trim around the clear plastic canopy at the molded-in trim lines, then trial fit it on the model. Trim or sand the back edge of the canopy until it fits perfectly against canopy former #2 (CF-2).
  - The die-cut Lite-Ply canopy former #1 (CF-1) has a dimple in the center to mark the correct position of the hole for the canopy hold-down dowel. Trim and bevel the bottom edge of CF-1 so that it sits on the back edge of the canopy base, dimple-side up, and rests directly on CF-2. Glue CF-1 to the canopy base using medium CA, being careful not to get any glue on the wing or fuselage.
  - Drill through CF-1 and CF-2 at the dimple with a 1/4" drill bit.
60. Push the 1/4" dia. x1/2" long canopy hold-down dowel (left over from step 47a) through the hole in CF1 until it extends just past the rear face of CF-2. Glue around the dowel to CF-1, being careful not to get any glue on CF-2.
- 61.
- Carefully trim or sand the edges of CF-1 for a perfect fit with the canopy. You may have to remove the canopy base/CF-1 assembly several times during this process, to avoid altering the shape of CF-2.
  - Remove the canopy base/CF-1 assembly from the airplane. Re-glue the canopy hold-down dowel from the back side of CF-1. When dry, sand the dowel off flush with the front face of CF-1.



62. The canopy interior is now ready to finish to your liking. Since it won't be exposed to fuel or exhaust, most any type of paint can be used on the wood and plastic. For best results, we recommend spraying light coats of Sig Supercoat Dope or Sig Skybrite. The wood can be covered with an iron-on plastic film, but don't try it on the canopy base (the heat from the iron will melt and distort the plastic). If you wish, you can add a pilot at this time - just be sure it fits under the clear canopy. A Williams Brothers 2" scale Sportsman pilot looks good, but needs to be sanded at the base to fit. Cut out the instrument panel from the decal sheet and apply it to the face of the console for that finishing touch.



- 63.
- When you're satisfied with the finish of your canopy interior, tape the assembly back in position along the outer edges of the canopy base.
  - Before gluing the canopy in place, make certain it's inside surface is clean - you won't be able to get at it later! The canopy can be glued to the canopy base and CF-1 with Wilhold RC-56 glue, Sig-Ment glue, or clear RTV silicone rubber. CA's will work, but will sometimes fog the plastic (CA accelerators will definitely fog the plastic). Tape the canopy in place and allow to completely dry.



- 64.
- Remove the canopy assembly from the model and trim away the canopy base flush with the edge of the flange on the canopy. Sand the edges smooth leaving about a 3/32" flange on the sides of the canopy.
  - The canopy hold-down screw will pass through the extended front flange. Tape the canopy in place on the model and carefully mark the location of the hole for the canopy hold-down screw. Be certain that the hole will pass directly through the center of the canopy hold-down block in the wing.
  - Drill through the canopy flange and canopy hold-down block at the same time with a 1/8" drill bit.
- 65.
- Remove the canopy from the model, then redrill the hole in the canopy hold-down block with a 3/16" dia. drill bit.
  - Assemble the 4-40 brass threaded insert, the 4-40 x 3/8" canopy hold-down screw, and the #4 flat washer as shown in the photo. Screw the entire assembly into the canopy hold-down block until the washer is flush against the top of the wing.
  - Remove the screw and washer leaving the threaded insert in the wing. (You may have to hold the edges of the washer with a pair of pliers while loosening the screw.) Secure the threaded insert to the wing with a drop or two of thin CA.



## Tail Surfaces

- 66.
- Locate the two pre-cut 1/4" balsa elevators and sand their trailing edges round, including their inner, angled edges.
  - Draw a hinge line centered on the leading edge of each elevator. Use a sanding block to bevel the front of the elevators using the hinge line as a guide.
  - Temporarily pin the elevators to the plans and mark where the 3/32" dia. music wire elevator joiner will attach. Remove the elevators, then drill and groove their leading edges to accept the elevator joiner. Sand the joiner wire and wipe it clean before gluing it to the elevators with Kwik-Set Epoxy. Be certain to keep the leading edges aligned as the glue dries.



67. a. Glue the 1/4"x1"x4-3/16" stab tips to the pre-cut 1/4" balsa stabilizer, and allow to dry. Sig Bond is recommended for this step because it sands easily.
- b. Use the plans to help align the elevators on the back edge of the stabilizer, then tape them together. Holding the die-cut Lite-Ply stab tip template (STT) in place, cut the curved tip of the stabilizer and elevator with a sharp modeling knife. Repeat for the other tip.

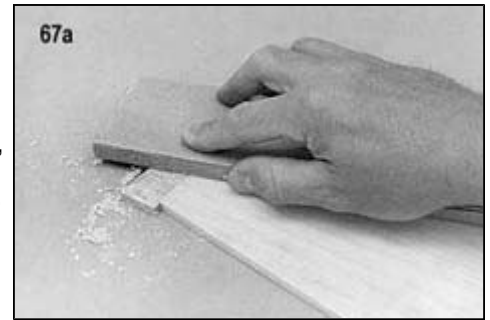

68. With the elevators still taped to the stabilizer, use a sanding block to round off the stab leading edges, stab tips, and elevator tips. Notice that the short length at the front of the stab should be left flat to fit against the back of F-6.

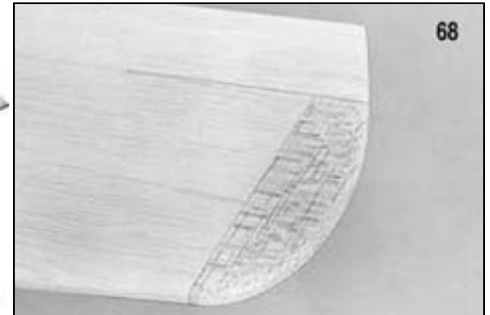
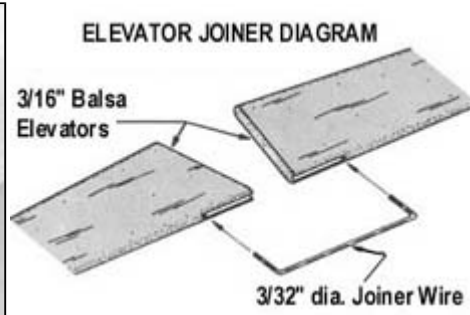

69. a. Sand the top front corner of the pre-cut 3/16" balsa fin to match the curve shown on the plan.
- b. Sand the fin leading edge round.
- c. Sand the trailing edge and bottom edge of the pre-cut 3/16" rudder round.
- d. Draw a hinge line centered on the leading edge of the rudder. Bevel the rudder leading edge using the hinge line as a guide.

70. The top of the fin or rudder may need sanding so that they line-up when installed. Temporarily pin or tape the stabilizer and fin on the back of the fuselage, then tape the rudder to the fin so that its bottom edge is aligned with the fuselage bottom. Remove the fin and rudder (which are still taped together) and sand the top edges until they match.

NOTE: If you are building the optional tail dragger version of the MID-STAR 40 proceed with step 71. Otherwise, skip step 71 and proceed to "Installing Easy Hinges".

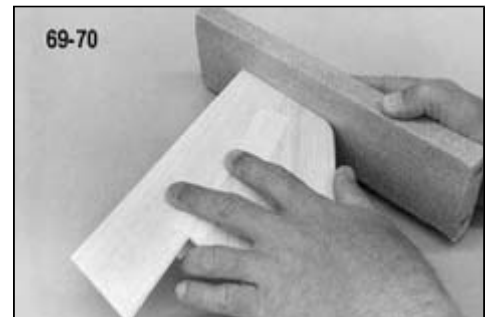

71. a. Notch and drill the bottom of the rudder to accept the tailwheel wire.
- b. Sand and wipe the tailwheel wire clean, then install it (without glue) on the rudder. Apply thin CA first (to penetrate) and follow up with slow CA to completely fill around the wire.
- c. Reinforce the tailwheel area with a 1-1/2" long piece of fiberglass tape wrapped around the bottom of the rudder. Use thin CA to completely saturate the tape and surrounding wood. A second coat of thin CA will help fill the weave of the fiberglass.



NOTE: Epoxy may be used in this step, but CA is faster and penetrates the entire tailwheel area, making it rock hard.

## COVERING

### General Instructions

Before choosing the covering for your model, please refer to the list of approved covering materials that has been included with this kit. The open-structure design of the Mid-Star 40 wing relies partially on the covering to aid in torsional stiffness, so it is very important that you use an approved covering material.

All of the Mid-Star 40 prototypes were covered with Sig Supercoat Iron-On Plastic Covering. Supercoat is ideal for sport models because it's lightweight and easy to apply. You will need two rolls of Supercoat to cover the model.

We recommend that you cover the wing, fuselage, tail surfaces, and control surfaces all separately before hinging and final assembly. This way the parts are much easier to handle.



The following instructions provide advice and procedures specific to the Mid-Star 40. If this is your first attempt at covering, be certain to read the two pages of step-by-step, photo-illustrated instructions included with each roll of Sig Supercoat. If you choose another brand of covering material, be sure to read the manufacturer's directions (supplied with the covering) and follow them carefully.

### Surface Preparation

A good covering job starts with good surface preparation. Regardless of what type of covering you choose, it won't hide poor workmanship. Any gaps around the tabs and slots in the fuselage should be filled with medium or slow CA. Fill any small surface gaps or dents with a lightweight filler or spackling paste. Sand the entire model, including the ailerons and tail surfaces, with 220-grit sandpaper, then again with 360 or 400-grit sandpaper.

Temporarily mount your engine on the model so that you can make cutouts as necessary in the side "cheeks" to clear the muffler and to allow access to needle valves, carburettor adjusting screws etc. When satisfied, remove the engine and touch up the cutouts with some sandpaper. Since it's too difficult to apply covering material inside the engine compartment, it must be fuel proofed using several coats of clear dope or two coats of polyester (glass) resin, sanded between coats. Finish off the engine area with a few coats of colored Sig Supercoat Dope. (Most of the Sig Supercoat Plastic Iron-On Covering colors have a matching Sig Supercoat Dope color).

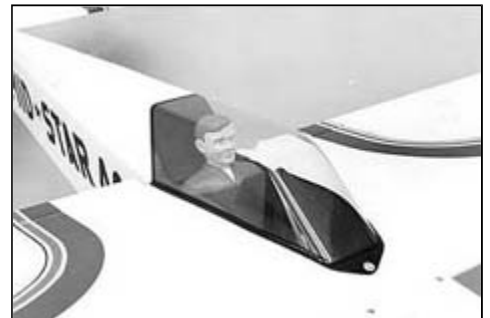

### Covering The Fuselage

The fuselage should be covered with seven pieces in the order described here:

- Fuselage Bottom - 1 pieces
- Fuselage Sides - 2 pieces, left and right
- Fuselage Top - 4 pieces, nose brace, hatch, stringers, CF-2

All seams should overlap about 3/16". When covering solid wood surfaces like the front of the fuselage sides, better results can be obtained by starting at the center and working toward the outer edges, allowing air to escape as you iron.

The trickiest part of covering the fuselage is the stringer area. Start by ironing the middle of your material to the top of the stringers, then work with each side separately. Carefully tack the material to the top edge of the fuselage side, then trim off the excess, leaving a 3/16" overlap. To avoid slicing into the material underneath, slide a piece of thin cardboard under the excess stringer covering before cutting it with a knife. Use a straight edge to make a nice, straight cut.

Go back over the side seams with your iron, then seal the material to the top edge of CF-2 at the front and F-6 at the back. Trim the excess at each end leaving an overhang of about 1/8" to iron around the corners. Seal down the 1/8" overhang to the front of CF-2 and back of F-6. Now you can use a heat gun or iron to shrink the rest of the material over the stringers. A small, separate piece of covering material can be applied to the front of CF-2 to improve its look and protect it from engine exhaust.

Experienced modelers know that oily engine exhaust likes to creep into every crack it can find, which means special care must be taken to keep the hatch area as fuel proof as possible. When you cover the hatch be sure to cover the front and rear edges, and wrap the material around both sides about 1/2". The bottom surface of the hatch and the plywood hatch tongue should be protected with a couple of coats of clear dope. The covering material on the fuselage sides should wrap around the top in the hatch area as well as the wing saddle area.

Another area that needs some clear dope for protection from exhaust is the rear side of the canopy former #1 (CF-1). For a finishing touch on the canopy, use some 3/16" wide striping tape, such as Sig SuperStripe, around the rear edge and along the side flanges.

### **Covering The Wing**

Begin the wing by covering the wingtips and plywood hold-down plates. Cover each wingtip with two pieces of material, first the bottom, then the top. Seal each piece securely to the end rib and wingtip edge before shrinking it tight. Later, when the main top and bottom covering pieces are applied, they will overlap the wingtip covering on the end rib.

Cover the hold-down plates with a single piece of material, extending it about 1/8" past the outside edges of the plates, again to provide an area for overlap.

Cover the main portion of the wing starting with the bottom and then the top so that the seams will be on the bottom where they will be less visible. The top covering should overlap the full width of the leading & trailing edge.

Wait until both the top and bottom pieces of covering material have been sealed completely around their edges before shrinking the large open areas between the ribs. Alternate between the top and bottom surface to avoid uneven shrinking which could cause a warp. Your sealing iron or a special "heat gun" can be used (household blow dryers don't provide enough heat). Keep the heat gun moving at all times or you may burn a hole in the covering. If you notice the covering material "ballooning up", put a small pin hole in the bottom of each rib bay to allow the expanding air to escape.



### **Covering The Tail Surfaces And Ailerons**

The stabilizer, elevators, fin, rudder, and ailerons should each be covered with two pieces of material - bottom first, then the top. Iron the material from the center out to avoid trapping air bubbles. Once the ailerons have been covered, cut away the material to expose the slot and hole for the torque rods.

### **Applying The Decals**

We recommend hinging the control surfaces before applying the decals. Instructions for decal application can be found in step 82



## INSTALLING EASY HINGES

---

Sig's famous EASY HINGES have been included with your kit to hinge all of the control surfaces. Each ultra-thin hinge is actually a three-part laminate - a tough plastic inner core sandwiched by an absorbant wicking material. They have been chemically treated to slow down the reaction of thin CA (which is normally instant), to allow the glue time to soak all the way to the ends of the hinge and into the wood surrounding it. Once the glue has dried, the hinge cannot be pulled from the structure without tearing wood out with it! We recommend that all surfaces be covered before hinging.

72. Using a No. 11 X-Acto blade (or similar), cut slots approximately 1/2" in depth and slightly wider than the hinges. Cut four slots in the stabilizer and four slots in the elevators at the locations shown on the plans.
73. After all of the slots have been cut, insert EASY HINGES halfway into the stabilizer slots. DO NOT GLUE THE HINGES YET! Next, carefully slide the elevators onto the hinges. You'll find it easiest to slide the elevators onto the hinges at an angle, one at a time, instead of trying to push it straight onto all of the hinges at once. Don't be concerned if the hinges aren't perfectly straight or centered in the slots - they don't have a centerline.
74.
  - a. To set the hinge gap, deflect the elevators to the maximum amount needed. For best control response, the gap should be as small as possible but big enough to allow full movement of the control surface.
  - b. EASY HINGES were designed to use THIN CA (any brand) for maximum glue penetration. Place three or four large drops of thin CA directly onto the hinges in the gap. The glue will wick into the slot as it penetrates both the wood and the hinge. Continue this process, gluing the same side of all of the hinges, then turn the stabilizer over and repeat the gluing process on the other side of each hinge.

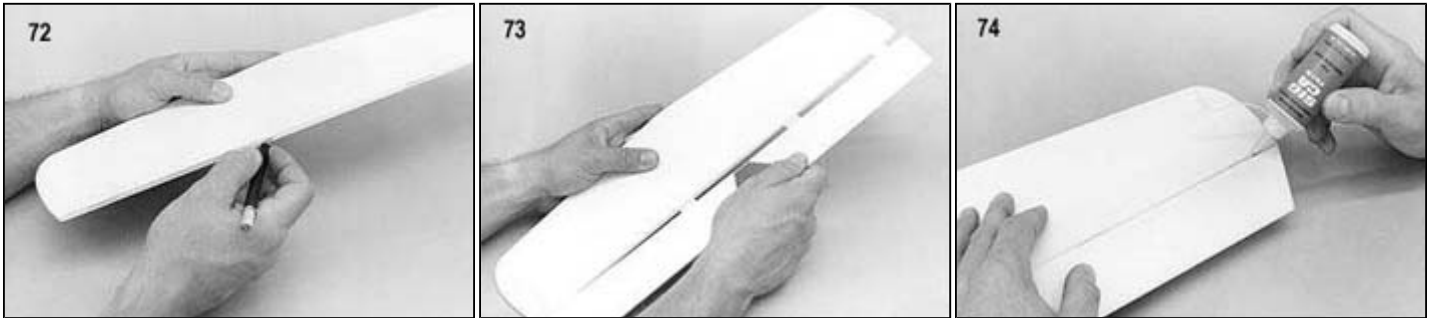

75. After the glue has cured (3 to 5 minutes) the joint should be flexed to full deflection in each direction a couple of dozen times to reduce the stiffness. Don't worry about shortening the life of the hinges, as they are almost indestructible.
76. The rudder is hinged in the same manner as above, but it is easier to install AFTER the fin has been glued to the fuselage. Cut slots for three hinges now (3 slots in the rudder, two in the fin, and one in the back of the fuselage).

NOTE: The fuselage slot may be difficult to cut, but don't be tempted to omit it. The bottom hinge is vital to the integrity of the rudder because it absorbs loads from both the servo and the tailwheel (if used). Jab the knife straight into the joint at the rear of the fuselage, pull it straight out, reposition it slightly, and repeat the procedure until you have a slot that's long enough for the hinge.
77. The ailerons are hinged exactly like the tail surfaces, but the torque rods must be glued as well. Start by cutting the slots in the wing and the ailerons (four per aileron) and install EASY HINGES halfway into the ailerons.
78.
  - a. Slide a small piece of wax paper between the torque rods and the wing. Working with one aileron at a time, apply Kwik-Set epoxy to the slot and hole in the aileron leading edge and slide it onto the torque rod, working the EASY HINGES into the wing slots at the same time. Try not to get any epoxy on the brass tubing! Before the glue sets, be sure to deflect the aileron back and forth to set the proper hinge gap.
  - b. Once the epoxy has dried, remove the wax paper and apply thin CA to the hinges as you did earlier.

## FINAL ASSEMBLY

---

79.
  - a. Temporarily position the stabilizer on the stab support at the back of the fuselage. Again refer to the General Alignment Diagram on page 20 of "The Basics of Radio Control". When satisfied with the alignment, draw cut lines on the bottom of the stabilizer at the fuselage sides. Remove the stabilizer and cut away the covering on the bottom where it will be glued to the fuselage using a sharp knife.
  - b. Glue the stabilizer to the fuselage using Kwik-Set epoxy. Recheck its alignment and adjust before the glue dries.

80. a. Cut away a 3/16" wide strip of material from the center of the stabilizer where the fin is to be glued. Epoxy the fin to the top of the stabilizer, using a triangle to check its alignment as it dries. Make certain that the back edge of the fin is lined-up with the back edge of the fuselage sides.  
 b. Hinge the rudder to the fin and fuselage using three EASY HINGES.

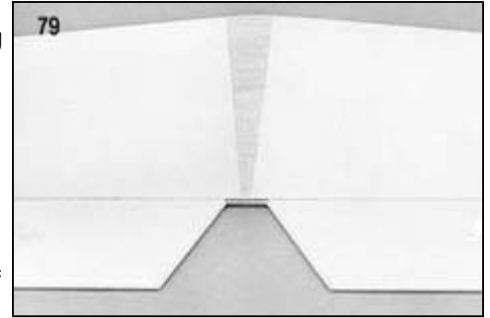

81. (OPTIONAL) Although the fin attachment method in the previous step has proven to be more than adequate on our test models, some modelers may want some extra strength in that area, particularly if they fly on a rough field where models have a tendency to flip over on their back. Then again, there are some of us who tend to flip our models over even on smooth fields! The optional fin braces shown in the photo aren't exactly pretty, but they do add a tremendous amount of strength to the area and are recommended for any Mid-Star 40 pilot who is more concerned with day-to-day hardknocks flying than with looks.

The fin braces can be cut from the 1/2" triangle stock provided in the kit and shaped as shown in the picture. Cover the outside face of the braces, and cut away the covering material on the fin and stabilizer before gluing the braces in place on each side of the fin.

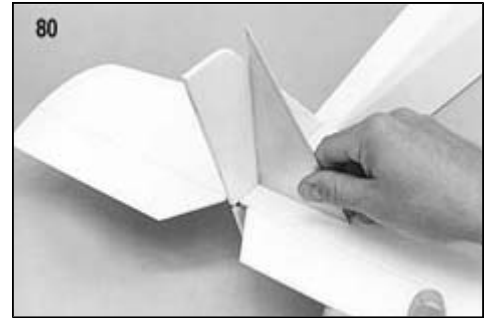

82. Now is a good time to apply the decals. Use the plans and photos of the finished model for proper positioning. Cut out the decals with scissors, leaving about 1/32" to 1/16" of clear at all edges and rounding the corners, as you cut. Wet the surface on which the decal will be placed with soapy water (use a couple of drops of dishwashing detergent in a small bowl of water). Place the decal on the model and squeegee the water from underneath with a balsa paddle. This procedure allows time for repositioning and prevents air from being trapped under the decal. Allow several hours to dry.

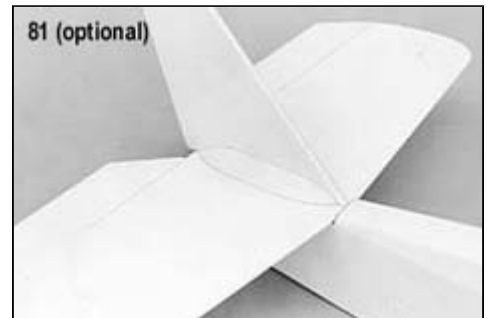

83. Install 2-3/4" main wheels on the aluminum landing gear using the hardware as shown on the plans. A drop of CA on the inner nut will help keep the assembly from vibrating loose. Once the wheels have been attached, the landing gear assembly can be bolted to the fuselage using four 4-40 x 1/2" mounting bolts. NOTE: If you are building the optional taildragger version of the MID-STAR 40, skip step 84 and proceed to step 85. If you are building the standard tricycle gear version, perform step 84, skip step 85, and proceed with step 86.



84. a. Bolt the nose gear bearing to the front of F-1. Install a 2-1/2" dia. wheel on the nose gear strut using two 5/32" wheel collars (not included, SIGSH587), then assemble the strut and steering arm to the nose wheel bearing. When putting the nose gear together, you can adjust the length of the wire strut a little if necessary to get the model to sit at the proper ground attitude (see page 21 of "The Basics Of Radio Control"). The MID-STAR 40 should sit on its tricycle gear so that the top edge of the Lite-Ply fuselage side (behind the wing) is perfectly level in relation to the ground. The adjustment is made by loosening the set screw in the steering arm and sliding the wire strut further in or out of the nose gear bearing. To prevent the steering arm from twisting on the strut, grind or file a small flat spot on the wire strut where the set screw makes contact.  
 b. Install the nose gear pushrod using the guidelines in "The Basics Of Radio Control" (page 9). To prevent unwanted flexing, the outer nylon tubing should be glued firmly to F-1, F-2, and a scrap balsa standoff at the end closest to the servo. The flexible cable is attached to the servo with a solder clevis, and to the steering arm with the pushrod connector which was installed earlier.

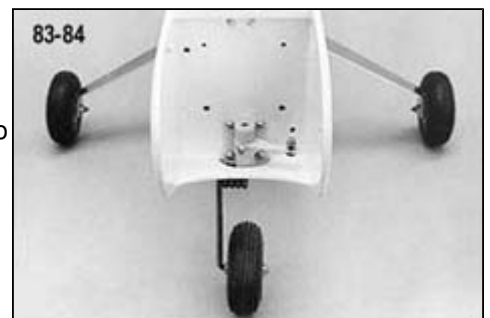

85. Install a 3/4" dia. tailwheel on the tailwheel wire using two 1/16" wheel collars (not included SIGSH584). A cleaner, but more difficult installation would be to solder small flat washers to the wire on both sides of the tailwheel. Solder the inner washer first, then slide the tailwheel in place followed by a temporary spacer made from thin cardboard. Solder the remaining washer, then remove the spacer when cool. Whether you use wheel collars or washers, trim off any excess tailwheel wire.

NOTE: The remaining section of these instructions concerning engine and fuel tank installation, radio installation, pre-flight checkout, and flying provide information that is specific to the MID-STAR 40. For a more in-depth look at any of these subjects, please refer to "The Basics Of Radio Control" booklet also included with this kit. In particular, it is strongly recommended that you go through the "Pre-Flight Checklist" in Chapter 7 carefully before attempting to fly.

## Engine And Fuel Tank Installation

Engine installation on the MID-STAR 40 is simply a matter of bolting the engine mounts that were prepared in step 28 to F-1, then bolting your engine to the mounts. Install the throttle pushrod using the guidelines in "The Basics Of Radio Control" (pages 8 - 9). Like the nosewheel pushrod, the outer nylon tubing of the throttle pushrod should be glued to F-1, F-2, and a scrap balsa standoff.

An 8 ounce fuel tank is recommended for the MID-STAR 40, although most tanks from 6 oz. to 10 oz. will work. Sullivan 8 to 10 oz. Slant type or RST type tanks will fit easily. A Du-Bro 10 oz. will not. Most engines will require the tank to be mounted as high as possible in the fuselage. Use foam rubber under the fuel tank as necessary to position it properly.

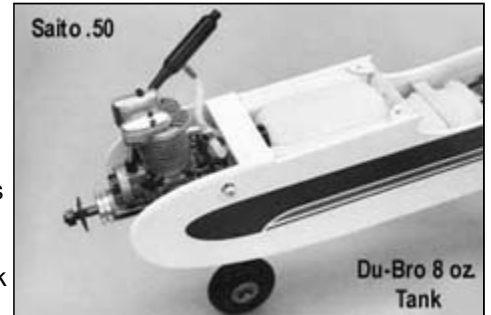

## Radio Installation

Screw the nylon control horns onto the rudder and elevator as shown on the plans, then re-install the inner nylon pushrods that you prepared in step 56. Snap an R/C link on the rudder horn, then cut off the excess nylon tubing, leaving a 1/8" gap between the end of the tubing and the R/C link. Cut a 2-56 x 10" threaded rod to an overall length of 3-1/2", measuring from the threaded end. Install the threaded rod in the nylon tubing, smooth end first, so that approximately 1/2" of the threaded portion remains exposed. (The metal rod will help prevent the nylon tubing from buckling under flight loads.) Thread the R/C link onto the end of the pushrod until the rudder is neutral, then repeat the procedure for the elevator .

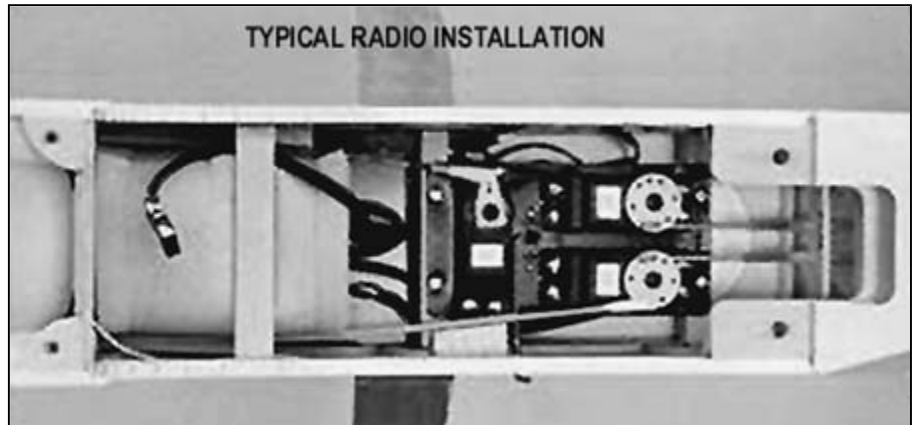

The aileron servo can be mounted to two 3/8" sq. x 1-1/2" basswood rails, as can be seen on the W-1 cross-section drawing on the plans. The nylon aileron connectors can be moved up or down the torque rods to adjust the amount of aileron throw. Tape the servo wire to the wing to keep it from getting tangled with the aileron servo, as well as the servos in the fuselage.

A typical radio installation is shown in the photo above. The receiver and battery on this model are wrapped in foam rubber and positioned just forward of the servos. A scrap balsa stick keeps them from moving around during flight. If you use a lightweight engine, you may need to install the battery under the fuel tank to achieve proper balance.

Notice that the aileron connector wire and the charging jack are left accessible, but are tucked away enough so that they can't interfere with the servo arms and linkages. The antenna has been routed away from all other wiring and out the fuselage side (opposite from the engine exhaust) and up to the top of the fin.

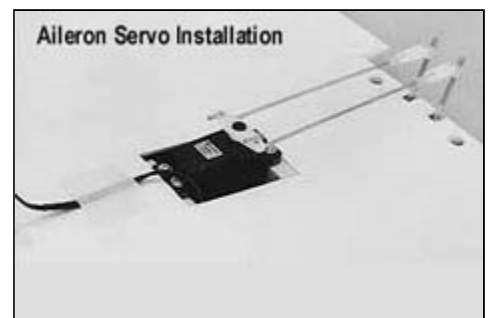

## Pre-Flight Checkout

IMPORTANT: For first flights, make certain that the model balances somewhere in the range shown on the plans. If it balances further back, add weight to the nose as necessary. Trying to fly with the balance point too far aft is much more dangerous than the slight increase in wing loading caused by adding lead to the nose. Always balance the model with an empty fuel tank.

Be certain to range check your radio equipment according to the manufacturer's instructions before attempting test flights. A lot of problems can also be avoided if your engine has been well broken-in and the idle adjustments perfected on a test stand or in another airplane before installation in the new model.

Before flying, you should adjust all of your push rod linkages so that the control surfaces are in their neutral position when the transmitter sticks and trim levers are centered. When you get to the field, don't be surprised if the elevator and rudder are suddenly misaligned. Temperature and humidity changes can cause the nylon push rod tubes to expand or contract slightly. Use the trim levers on the transmitter to reneutralize the control surfaces, and do the final trimming in the air.

The control surface movements listed are recommended for the first flight of your MID-STAR 40. These movements will provide the model with a fair degree of aerobatic capability if it's balanced correctly. Test flights may indicate a need for slightly more or less movement, depending on individual model performance and personal preference.

<b>RECOMMENDED CONTROL SURFACE MOVEMENTS</b>	
For test flying, the following are suggested:	
<b>ELEVATOR</b>	1/2" UP and 1/2" DOWN
<b>RUDDER</b>	1" LEFT and 1" RIGHT
<b>AILERON</b>	3/8" UP and 5/16" DOWN

#### **WARNING - DANGER Important: Read These Warnings:**

Do not fly control line or towline models within 300 feet of electric power lines, instant death from electrocution can result from coming close to them. Direct contact is not necessary.  
 A model airplane motor gets very hot and can cause serious burns. Do not touch the motor during or after operation. Keep clear of the propeller, it can cut off a finger or put out an eye. Make sure the propeller is securely fastened in place and is not cracked. Model airplane fuel is flammable and poisonous. Take the same precautions while transporting and using it that you would with a can of gasoline or a bottle of poison.  
 Remember that it is possible to lose control of a model airplane. Do not fly in locations where the model may hit people or damage property if loss of control occurs. Check your model and equipment regularly to insure it is in safe operating condition.

## **FLYING**

The MID-STAR 40 is a fun aircraft to fly, but it is not a basic trainer. If you have no previous R/C flying experience, we suggest that you not attempt to fly this model without the assistance of an experienced pilot. Contact your local club or ask your hobby dealer for the names of good fliers in your area and a suitable location for flying.



When you are ready for takeoff, point it into the wind and apply throttle. You'll probably need a touch of right rudder to keep it going straight because engine torque will try to make it drift to the left. When you reach flying speed, pull back slightly on the elevator stick for a gentle liftoff.

If you are using a relatively large engine, don't expect the takeoff roll to last very long! With its big wing, the MID-STAR 40 likes to jump into the air and get down to business!

During the first part of the flight, concentrate on trimming the model to fly straight and level. Novices should spend time flying around smoothly and getting used to the "feel" of their new airplane. Experienced modelers will find the model capable of almost any trick "in the book". Experiment with different throws and balance points until the model flies exactly the way you want. Make any changes, especially to the balance point, gradually.

We recommend that you shift the balance point no more than 1/8" at a time. In general, moving the balance point forward will make the model more stable, slowing down snap rolls and spins. Moving the balance point back increases its sensitivity to control inputs; but if carried too far, the model can become completely unstable and uncontrollable. The balance range shown on the plans is a "safe" area to use for test flights. Don't exceed the rearward limit unless you are a very experienced pilot





When landing be ready to go around if it looks like you're going to overshoot the runway. It will take a few flights to get a feel for the correct approach and landing speed. Remember to keep your control inputs smooth and gentle to avoid overcontrolling.

When you are certain the model will make it to the runway (even if the engine quits), bring the throttle to full idle and concentrate on keeping the wings level during final approach. Slow the model down during the entire approach by slowly feeding in up elevator. Just before the model touches, flare the landing by carefully feeding in more up elevator. Hold the model just inches off the ground until your elevator stick is pulled all the way back. The MID-STAR 40 should settle in for a perfect nose-high landing with a short rollout.

**MODELER'S TIP:**

The canopy gives the MID-STAR 40 its stylish look. Just don't forget to take it with you to the flying field! The small screw and washer that hold the canopy in place should be kept in the wing at all times, so that they don't get misplaced.

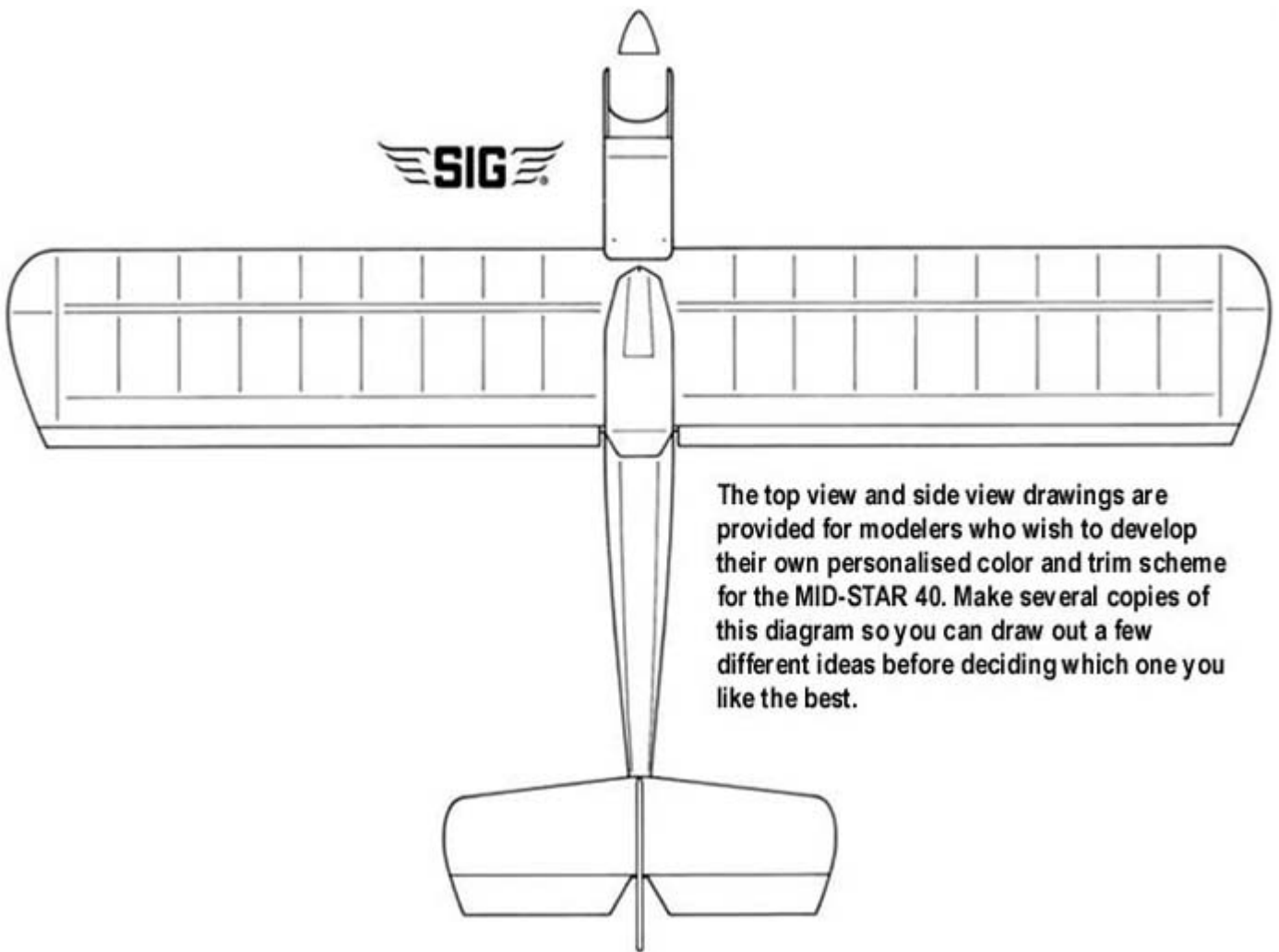



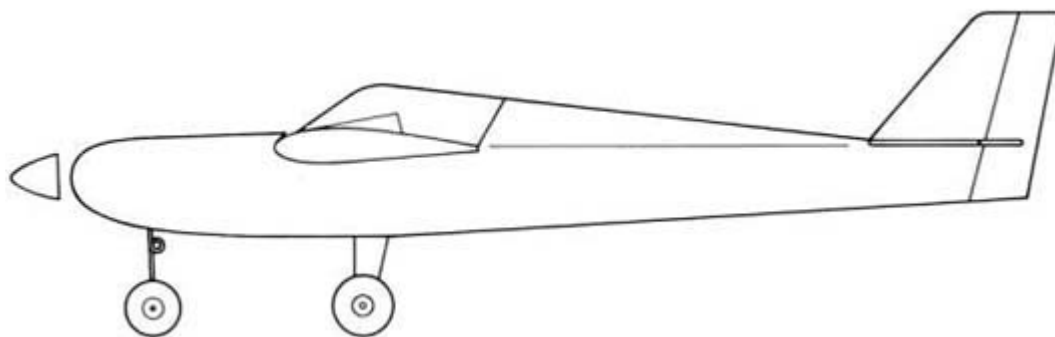

If you have any technical questions or comments about this kit, or any other SIG product, please call us.

**SIG MODELER'S HOTLINE**  
**1-800-524-7805**  
**Weekdays, 7:00am - 4.30pm Central**

---

© Copyright SIG Mfg. Co., Inc.

**SIG MFG. CO., INC.....Montezuma, Iowa 50171-0520**

**LIMIT OF LIABILITY:**

In use of our products, Sig Mfg. Co.'s only obligation shall be to replace such quantity of the product proven to be defective. User shall determine the suitability of the product for his or her intended use and shall assume all risk and liability in connection therewith.